

# TAPMATIC

TAPPING



MARKING



DEBURRING



**effectivity tools**



Quality, reliability and good service are what TAPMATIC stands for



Allan, Eric, and Andrew Johnson

**Tapmatic Celebrates 70 years of Innovation!**

Tapmatic was founded in 1952 by my grandfather, Andrew Johnson and his sons Eric and Allan. My father Allan is a self-taught Engineer. He designed the original Tapmatic reversing tapping attachment and a wide range of other products including drill speeders, polishing lathes, and even the worlds most powerful spear gun. He has received more than 50 patents worldwide. After the passing of Eric and Andrew in 1968, Allan took over management of the company and the marketing of our products, introducing the Tapmatic brand to manufacturing companies all over the world. His tradition of innovation, and enthusiasm for developing friendships with people in other countries, continue to inspire us today. Allan retired from the day to day business in 1993, but thanks to him, we are proud to be an American exporter with half our sales to customers outside the United States. After 70 years in business we would like to take this chance to thank our friends, colleagues and customers for all your support over the years. We are very grateful to still be working together with you.

Mark Johnson  
President



*We're not just tapping!*

Now Tapmatic also offers a complete program of marking tools. Whether your application calls for dot peen marking, scribing, or stamping, our tools allow you to mark the work piece during the machining process. Mark it while you make it.

Tapmatic is pleased to introduce the new DeBurr-Z for deburring and chamfering operations on your CNC machine.



Tapmatic Corporation is an ISO 9001 certified company.



TAPMATIC Post Falls, USA

	<p>Description</p> <p><b>Synchronized Tapping</b>  <b>SynchroFlex®</b> For rigid, or synchronized tapping on CNC machines with or without internal coolant, or with minimum quantity lubrication (MQL). ER collet or Quick Change Spindles.</p>	<p>Model</p> <p>Introduction                      SFT (Internal Coolant)                      SFT (MQL)</p>	<p>Page</p> <p>4-7                      8-12                      13</p>
	<p><b>Tension compression tap chucks</b>                      For use on CNC machining centers, lathes and all machines with controlled feed when tapping cycle is not synchronized.</p>	<p>Introduction                      SM                      TA                      TIC</p>	<p>14                      15                      16                      17</p>
	<p><b>Self-reversing CNC tapping attachments</b>                      For vertical and horizontal CNC machining centers, for continuous production. Extended spindles and interchangeable shanks available.</p>	<p>Introduction                      RDT 25                      RCT                      Installation</p>	<p>18-19                      20                      21-22                      23</p>
	<p><b>Self-reversing manual tapping attachments with pre-selective torque drive</b>                      Automatic reverse with increased reverse ratio. For manually operated drilling and milling machines.</p>	<p>Introduction                      Drill-n-Tap                      RxII                      90X</p>	<p>24                      25                      26                      27</p>
	<p><b>Effectivity Tools</b>  <b>In machine marking</b>                      Marking tools for in machine marking. Dot peen marking tool. Scribing tool. Stamping head.  <b>In machine deburring</b>                      Floating tool holder for CNC deburring.</p>	<p>Introduction                      TapWriter                      Scribe Writer                      MH                      DeBurr-Z</p>	<p>28-29                      30-31                      32-33                      34-35                      36-39</p>
	<p><b>Quick-change adapters</b>                      Modular accessories, compatible with the respective tapping attachment or chuck.</p>	<p>P - positive drive                      TC - torque control                      TF - rubber flex</p>	<p>40-41                      42-43                      44</p>
	<p><b>Various accessories</b>                      For use on attachments and chucks.</p>	<p>Rubber flex collets                      ER-GBTap Collets                      ER Standard Collets                      Clamping nuts                      Sealing disks</p>	<p>44                      45-46                      47                      48                      48</p>
	<p><b>Various accessories</b>                      For installation of attachments and chucks on various machines.</p>	<p>Torque wrenches                      Torque Bars                      Clamping device                      CNC Shanks                      Arbors</p>	<p>49                      49                      49                      50                      51</p>
<p><b>Information</b></p>	<p>ER Clamping                      Safety                      Warranty                      Application Questionnaire</p>	<p>52                      53                      53                      55</p>	



## Tap holders for synchronized tapping cycles



Modern CNC machines have the capability of synchronizing the spindle rotation to match the feed advance for a specific tap pitch. The «Rigid» or synchronized tapping cycle is very accurate, but it is impossible to avoid small discrepancies between the machine synchronization and the actual pitch of the specific tap being used. Using a rigid tap holder means that any deviation at all increases the thrust forces acting on the tap and this dramatically reduces tap life.

### **SynchroFlex® –The Unique Solution**

At the heart of SynchroFlex® is a precisely machined flexure which provides axial and radial compensation for the unavoidable discrepancy between the machine feed advance and the actual tap pitch. By compensating for this error, the thrust forces acting on the tap are dramatically reduced. The result is the longest possible tap life, 100% improvement or more, and much better quality threads.

### **SynchroFlex® II with increased flow rates for high pressure internal coolant.**

Tapmatic's 80 bar, balanced, internal coolant system is included in all SynchroFlex tap holders and our system does not influence the axial compensation forces. The holders may be used with or without internal coolant.





**Design and Development**

Flexure geometries have been designed using the ANSYS finite element analysis method in order to achieve the optimal force vs. deflection rates for the tap capacity of each holder.

**SynchroFlex® – Force vs. Deflection Rates**

Unlike competitors that employ elastomer rings to provide a small amount of axial compensation ( $\pm 0.5$  mm), the SynchroFlex® flexure has a consistent force vs. deflection rate. This means consistently superior tap life and thread quality.

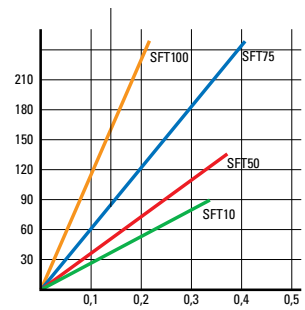

By limiting the axial compensation travel, and torsional forces acting on the flexure, millions of holes can be tapped without causing the SynchroFlex® holder to fatigue, take a set, or wear out. Below is an example of stress analysis at maximum compression

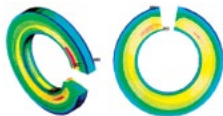

Axial micro compensation is closely limited (mechanically secured)

Torque is transmitted through the drive pins – not through the flexure.

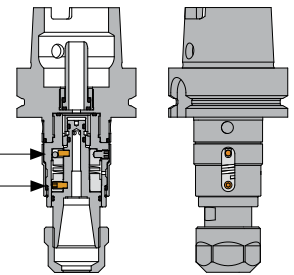

**Comparison tapping with an M6 spiral fluted tap in 6061 Aluminum to depth of 18 mm.**

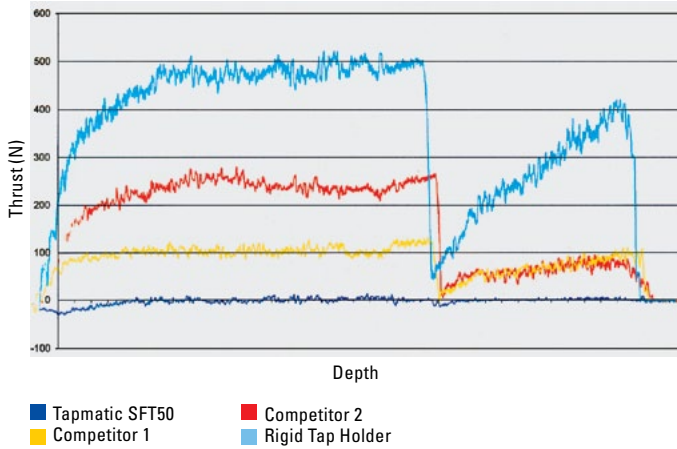

**Test Results**

SynchroFlex® tap holders have been tested by tap manufacturers all over the world and they have confirmed the dramatic improvement in tap life, and thread quality resulting from the reduction of thrust forces acting on the tap.

The graph to the left is an example of a test conducted by an independent tap manufacturer using a Kistler dynamometer to measure the thrust forces during the tapping process. As you can see from the graph, although the competitive holders do reduce thrust forces compared to a rigid tap holder, they are not as effective as SynchroFlex®.

**Case History**

**Application:** Thread cutting on horizontal machining center rigid tapping during an unmanned shift.

**Material:** 42CrMo4V steel, heat treated to 650 N/mm2

**Tap Size:** M8 x 1

**Lubrication:** Coolant, oil emulsion 6%

**Results:** With the tap held in a rigid holder the life was just 1'000 components per tap.

**Improvement with SynchroFlex®**

Tap life increased to 2'400 to 2'900 components per tap saving the customer not only in tap costs, but the ability to run without interruption through the entire unmanned shift.

**Case History**

**Application:** Thread cutting on machining center rigid tapping.

**Material:** CF8M steel casting

**Tap Size:** #10-32

**Lubrication:** Coolant

**Results:** With the tap held in a rigid holder the life was just 72 holes per tap.

**Improvement with SynchroFlex®**

Tap life increased to more than 216 holes per tap in this difficult material saving the customer not only in tap costs, but by also reducing his down time caused by frequent tap replacement.

**Total cost/year**

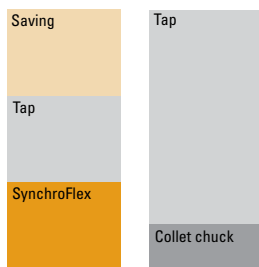

**Break Even Point**

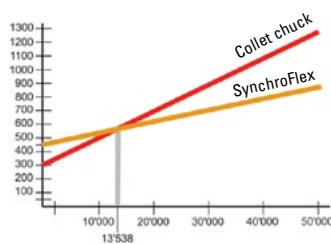

**Total cost/year**

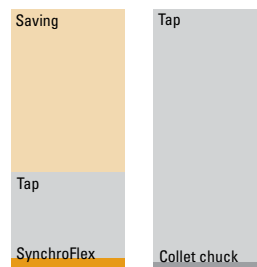

**Break Even Point**

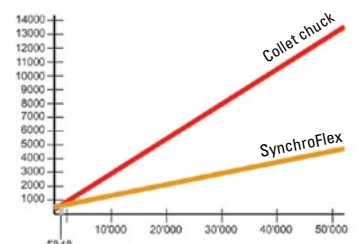

Overview of the SynchroFlex® program



Pictured with ER-collet, spindle and straight shank

Six Sizes to Cover a Wide Range of Taps

- SFT II 5 with capacity M1–M3
- SFT II 10 with capacity M2–M5
- SFT II 50 with capacity M4–M12
- SFT II 75 with capacity M8–M20
- SFT II 100 with capacity M16–M30
- SFT II 150 with capacity M22–M48

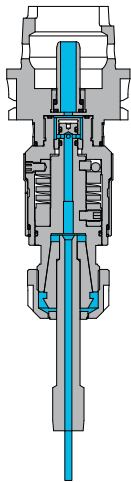

SFT II  
High Pressure Internal Coolant  
with increased flow rates

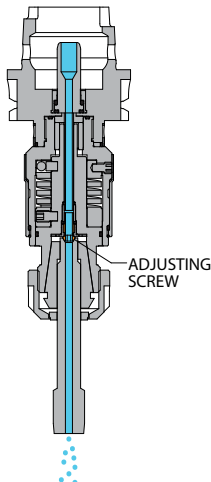

Minimum Quantity Lubrication  
Available for 1 channel or  
Multi channel systems

Internal Coolant and MQL

Tapmatic's high pressure internal coolant system may be used at pressures up to 80 bar without affecting the axial compensation.

Tapmatic also can provide tools ready for Minimum Quantity Lubrication through the spindle. Our system provides direct flow of air and lubricant to the back of the tap. See page 13.

Available with QC spindle

Accepts the standard Quick Change adapters or Tapmatic's ER collet chuck QC adapters for improved tap grip.



Integral shank models

Tapmatic offers standard integral shank HSK and Tapmatic Capto tools. ABS shanks are also available on request.



We can also offer integral Steep Taper shank tools but in most cases we recommend a modular system using a cylindrical shank SynchroFlex® together with our Short Projection SK, BT or CAT shank.

No hole beyond your reach

Four standard extensions are available which increase the tool length by 50, 100, 150, or 200 mm.

Special extensions are also available to fit your specific application. Our extensions keep the flexure in close proximity to the tap ensuring the best performance.



Synchronized Tapping



Synchronous feed tap holders with modular straight shank, with internal coolant system



ER Collet Chuck



Quick-Change

Features and Advantages

- increase tap life by 100% or more
- improves thread quality
- reduces downtime by lowering frequency of tap replacement
- Axial compensation +/- 0.5mm (SFT II 150 +/- 1.5mm)
- wide range of sizes
- available with ER collet or Quick Change chuck
- Tapmatic's 80 bar, balanced, high pressure internal coolant system is included. Coolant pressure does not influence axial compensation.

How to Order

Please select the tap holder (A) and SK or BT shank (B), to fit your machine. For Quick Change models order ER collet adapter (C) shown below or standard adapters shown in accessories section. Please order accessories like collets and sealing gaskets separately as they are not included.

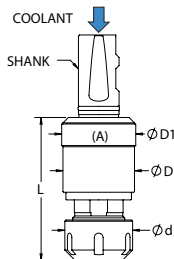
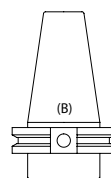

(A) Tap Holder SFTII Cylindrical Shank, ER Collet Chuck, Internal Coolant System

Model	Capacity (steel)	Collets	Shank	Order code (nut w/o seal)	Order code (with seal nut)	L (nut w/o seal)	L (with seal nut)	Weight kg	D	D1	d
SFT II 5	M1-M3 #00-#5	ER8	12 mm	41051208		28		0.1	12.0	12.0	12
SFT II 10	M2-M5 #2-#10	ER11	25 mm	41102511		52		0.4	23.5	23.5	19
			1"	41101111							
			20 mm	41102011							
			16 mm	41101611							
SFT II 50	M4.5-M12 #8-1/2"	ER20	25 mm	41502520N	41502520	64	69	0.5	34.6	36.3	34
			1"	4150120N	4150120						
			20 mm	41502020N	41502020						
SFT II 75	M8-M20 1/4"-3/4"	ER25	25 mm	41752525N	41752525	83	88	1.0	44.0	45.6	42
			1"	4175125N	4175125						
SFT II 100	M16-M30 5/8"-1"	ER40	25 mm	411002540N	411002540	112	117	2.0	62.0	63.6	63
			1"	41100140N	41100140						
SFT II 150	M22-M48 7/8"-1 7/8"	ER50	40 mm	411504050N	411504050	159	167	5.1	80.0	86.0	78

\*Note: Availability of inch size ER50GB collets is limited. Please consult a Tapmatic sales representative for sizes currently available. These internal coolant tools come standard with sealing nut, but tools with standard nuts are also available. When using Roll Form Taps the tool's capacity must be reduced 25%. All dimensions are shown in mm. 25.4mm = 1".

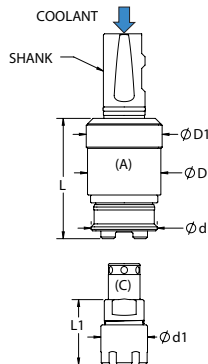

(A) Tap Holder SFTII Cylindrical Shank, Quick-Change Internal Coolant System

Model	Capacity (steel)	Adapter	Shank	Order code	L	Weight kg	D	D1	d
SFT II 10	M2-M5 #2-#10	Nr. 0	25 mm	411025QC	54.5	0.4	23.5	23.5	25
			1"	41101QC					
			20 mm	411020QC					
			16 mm	411016QC					
SFT II 50	M4-M12 #8-1/2"	Nr. 1	25 mm	415025QC	56	0.5	34.6	36.3	35
			1"	41501QC					
SFT II 75	M8-M16 1/4"-5/8"	Nr. 1	25 mm	417525QC	72	1.0	44.0	45.6	40
			1"	41751QC					
SFT II 100	M22-M48 7/8"-1 7/8"	Nr. 2	25 mm	4110025QC	105	2.0	62.0	63.6	59
			1"	411001QC					

Note: When using Roll Form Taps the tool's capacity must be reduced 25%. All dimensions are shown in mm. 25.4mm = 1". For best performance we recommend ER collet adapters shown below.

(C) ER collet adapter



Order code with Standard Nut	Adapter	Collets	d1	L1	Order code with Seal Nut	L1 (BCS)
8138211N	Nr. 0	ER11	19	20		
8208216	Nr. 1	ER16	22	24	8208216S	28
8218220	Nr. 1	ER20	28	35	8218220S	40
8288225	Nr. 2	ER25	35	38	8288225S	43
8288232	Nr. 2	ER32	50	48	8288232S	53



## Synchronous feed tap holders with integral HSK shank, with internal coolant system



### Features and Advantages

- increase tap life by 100% or more
- improves thread quality
- reduces downtime by lowering frequency of tap replacement
- Axial compensation +/- 0.5mm
- wide range of sizes
- available with ER collet or Quick Change chuck
- Tapmatic's 80 bar, balanced, high pressure internal coolant system is included.
- Coolant pressure does not influence axial compensation
- also available for Minimum Quantity Lubrication (MQL) through the spindle. Please see page 13

### How to Order

Please select the tap holder (A) including the HSK shank, to fit your machine. For Quick Change models order ER collet adapter (C) shown below or standard adapters shown in Accessories section. Please order accessories like collets and sealing gaskets separately as they are not included.

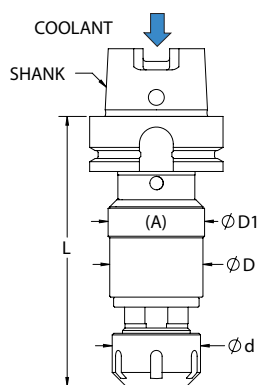

### (A) Tap Holder SFTII HSK Shank, ER Collet Chuck, Internal Coolant System

Model	Capacity (steel)	Collets	Shank	Order code (with seal nut)	L	Weight kg	D	D1	d
SFT II 50	M4-M12 #8-1/2"	ER20	HSK63A	4150H6320	108	1.0	34.6	36.3	34
			HSK80A	4150H8020	113	1.9			
			HSK100A	4150H10020	115	2.7			
SFT II 75	M8-M20 1/4"-3/4"	ER25	HSK63A	4175H6325	128	1.6	44.0	45.6	42
			HSK80A	4175H8025	131	2.4			
			HSK100A	4175H10025	133	3.2			
SFT II 100	M16-M30 5/8"-1"	ER40	HSK63A	41100H6340	160	2.2	62.0	63.6	63
			HSK80A	41100H8040	161	2.9			
			HSK100A	41100H10040	163	3.7			

**Note:** These internal coolant tools come standard with sealing nut, but tools with standard nuts are also available. When using Roll Form Taps the tool's capacity must be reduced 25%. All dimensions are shown in mm. 25.4mm = 1".

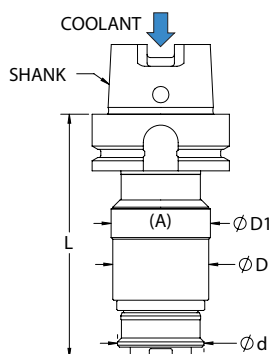

### (A) Tap Holder SFTII HSK Shank, Quick-Change, Internal Coolant System

Model	Capacity (steel)	Adapter	Shank	Order code	L	Weight kg	D	D1	d
SFT II 50	M4-M12 #8-1/2"	Nr. 1	HSK63A	4150H63QC	95	1.0	34.6	36.3	35
			HSK80A	4150H80QC	100	1.9			
			HSK100A	4150H100QC	102	2.7			
SFT II 75	M8-M16 1/4"-5/8"	Nr. 1	HSK63A	4175H63QC	112	1.6	44.0	45.6	40
			HSK80A	4175H80QC	115	2.4			
			HSK100A	4175H100QC	117	3.2			
SFT II 100	M16-M30 1/2"-7/8"	Nr. 2	HSK63A	41100H63QC	148	2.2	62.0	63.6	59
			HSK80A	41100H80QC	149	2.9			
			HSK100A	41100H100QC	151	3.7			

**Note:** When using Roll Form Taps the tool's capacity must be reduced 25%. All dimensions are shown in mm. 25.4mm = 1". For best performance we recommend ER collet adapters shown below.

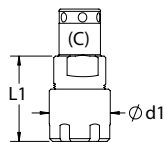

### (C) ER Collet Adapter

Order code with Standard Nut	Adapter	Collets	d1	L1	Order code with Seal Nut	L1
8208216	Nr. 1	ER16	22	24	8208216S	28
8218220	Nr. 1	ER20	28	35	8218220S	40
8288225	Nr. 2	ER25	35	38	8288225S	43
8288232	Nr. 2	ER32	50	48	8288232S	53



Synchronous feed tap holders with Tapmatic Capto shank, with internal coolant system

Synchronized Tapping

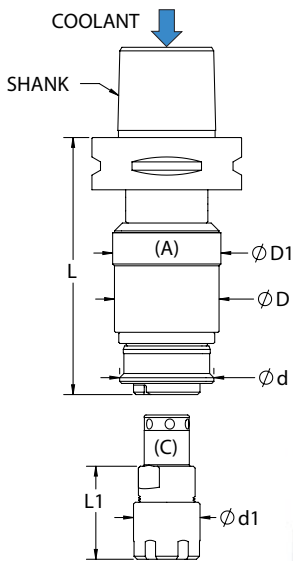
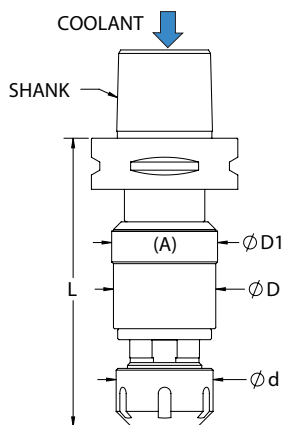

Features and Advantages

- increase tap life by 100% or more
- improves thread quality
- reduces downtime by lowering frequency of tap replacement
- Axial compensation +/- 0.5mm
- wide range of sizes
- available with ER collet or Quick Change chuck
- Tapmatic's 80 bar, balanced, high pressure internal coolant system is included. Coolant pressure does not influence axial compensation.

How to Order

Please select the tap holder (A) including the Tapmatic Capto shank, to fit your machine. For Quick Change models order ER collet adapter (C) shown below or standard adapters shown in Accessories section. Please order accessories like collets and sealing gaskets separately as they are not included.

(A) Tap Holder SFT II Tapmatic Capto Shank, ER Collet Chuck, Internal Coolant System

Model	Capacity (steel)	Collets	Shank	Order code (with seal nut)	L	Weight kg	D	D1	d
SFT II 50	M4-M12 #8-1/2"	ER20	C4	4150C420	102	0.7	34.6	36.3	34
			C5	4150C520	103	1.0			
			C6	4150C620	105	1.2			
			C8	4150C820	112	2.1			
SFT II 75	M8-M20 1/4"-3/4"	ER25	C5	4175C525	122	1.2	44.0	45.6	42
			C6	4175C625	124	1.5			
			C8	4175C825	131	2.4			
SFT II 100	M16-M30 5/8"-1"	ER40	C6	41100C640	154	2.9	62.0	63.6	63
			C8	41100C840	161	3.8			

**Note:** These internal coolant tools come standard with sealing nut, but tools with standard nuts are also available. Please add N to part number to specify nut without sealing. When using Roll Form Taps the tool's capacity must be reduced 25%. All dimensions are shown in mm. 25.4mm = 1"

(A) Tap Holder SFT II Tapmatic Capto Shank, Quick-Change, Internal Coolant System

Model	Capacity (steel)	Adapter	Shank	Order code	L	Weight kg	D	D1	d
SFT II 50	M4-M12 #8-1/2"	Nr. 1	C4	4150C4QC	89	0.7	34.6	36.3	35
			C5	4150C5QC	90	1.0			
			C6	4150C6QC	92	1.2			
			C8	4150C8QC	99	2.1			
SFT II 75	M8-M16 1/4"-5/8"	Nr. 1	C5	4175C5QC	106	1.2	44.0	45.6	40
			C6	4175C6QC	108	1.5			
			C8	4175C8QC	115	2.4			
SFT II 100	M16-M30 1/2"-7/8"	Nr. 2	C6	41100C6QC	142	2.9	62.0	63.6	59
			C8	41100C8QC	149	3.8			

**Note:** When using Roll Form Taps the tool's capacity must be reduced 25%. All dimensions are shown in mm. 25.4mm = 1". For best performance we recommend ER collet adapters shown below.

(C) ER Collet Adapter

Order code with Standard Nut	Adapter	Collets	d1	L1	Order code with seal nut	L1
8208216	Nr. 1	ER16	22	24	8208216S	28
8218220	Nr. 1	ER20	28	35	8218220S	40
8288225	Nr. 2	ER25	35	38	8288225S	43
8288232	Nr. 2	ER32	50	48	8288232S	53



Steel Collets



Sealing Gaskets



## Synchronous feed tap holders with VDI shank, with internal coolant system



### Features and Advantages

- increase tap life by 100 % or more
- improves thread quality
- reduces downtime by lowering frequency of tap replacement
- Axial compensation +/- 0.5mm
- wide range of sizes
- Tapmatic's 80 bar, balanced, high pressure internal coolant system is included. Coolant pressure does not influence axial compensation.

### How to Order

Please select the tap holder (A) including the VDI shank, to fit your machine. Please order accessories like collets and sealing gaskets separately as they are not included.

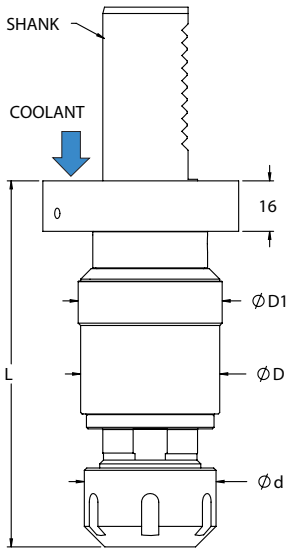

(A) Tap Holder SFT II VDI Shank, ER Collet Chuck, Internal Coolant System

Model	Capacity (steel)	Collets	Shank	Order code (with seal nut)	L	Weight kg	D	D1	d
SFT II 50	M4-M12 #8-1/2"	ER20	VDI 30	4150VDI3020	97	1.2	34.6	36.3	34
			VDI 40	4150VDI4020	97	2.1			
SFT II 75	M8-M20 1/4"-3/4"	ER25	VDI 30	4175VDI3025	116	1.5	44	45.6	42
			VDI 40	4175VDI4025	116	2.4			

**Note:** These internal coolant tools come standard with sealing nut, but tools with standard nuts are also available. Please add N to part number to specify nut without sealing.  
When using Roll Form Taps the tool's capacity must be reduced 25%.  
All dimensions are shown in mm. 25.4mm = 1"

Synchronized Tapping



**Synchronous feed tap holders with extended length, with internal coolant**

Synchronized Tapping

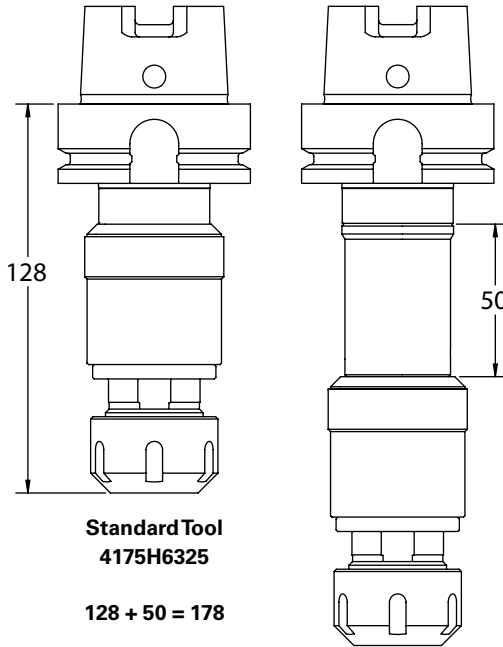

**Standard Tool  
4175H6325**

$128 + 50 = 178$

**Extended Tool  
4175H63L17825**

**Features and Advantages**

- four standard extensions of 50, 100, 150 and 200 mm
- increased tap life of 100% or more
- improved thread quality
- reduced downtime by lowering frequency of tap replacement
- Axial compensation +/- 0.5mm
- Tapmatic's 80 bar, balanced, high pressure internal coolant system is included. Coolant pressure does not influence axial compensation

**How to Order**

Please select the standard length SFT50 or SFT75, including the integral shank of your choice. Then choose a standard extension of 50, 100, 150 or 200mm. The order code is given as shown in the example drawing at left. Accessories like steel collets and sealing gaskets are not included. Please order these separately.

Special length extensions are also available upon request.

**Synchronous feed tap holders with reduced diameter and extended length**

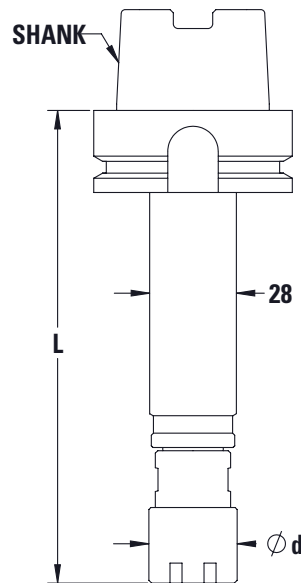

**Features and Advantages**

- special reduced diameter extended length tools for difficult to reach holes
- increased tap life of 100% or more
- improved thread quality
- reduced downtime by lowering frequency of tap replacement
- Axial compensation +/- 0.5mm
- available with internal coolant pressure up to 50 bar
- available with ER16 or ER20 mini nut collet chuck

**How to Order**

Please simply let us know the type of shank, length (L), and your preference of the ER16 or ER20 collet chuck. Please note diameter "d" for ER16 mini nut is 22mm and for ER20 it is 26mm. Accessories like steel collets and sealing gaskets are not included. Please order these separately.



Steel Collets



Sealing Gaskets

Synchronous feed tap holders with integral HSK shank, with MQL, minimum quantity lubrication

Synchronized Tapping



Features and Advantages

- increase tap life by 100% or more
- improves thread quality
- precise lubrication delivery for improved tool life
- reduce coolant and maintenance costs
- environmentally friendly alternative to recirculating coolant
- standard for one channel system, but multi-channel also available

How to Order

Please select the tap holder (A) including the HSK shank, to fit your machine. Please order accessories like collets, adjusting screws and sealing gaskets separately as they are not included.

(A) Tap Holder SFTII HSK Shank, ER Collet Chuck, MQL, minimum quantity lubrication system

Model	Capacity (steel)	Collets	Shank	Order code for MQL version	L	Weight kg	D	D1	d
SFT II 50	M4-M12 #8-1/2"	ER20	HSK63A	4150H6320M	108	1.0	34.6	36.3	34
			HSK80A	4150H8020M	113	1.9			
			HSK100A	4150H10020M	115	2.7			
SFT II 75	M8-M20 1/4"-3/4"	ER25	HSK63A	4175H6325M	128	1.6	44.0	45.6	42
			HSK80A	4175H8025M	131	2.4			
			HSK100A	4175H10025M	133	3.2			

**Note:** These MQL tools come standard with sealing nut. When using Roll Form Taps the tool's capacity must be reduced 25%. All dimensions are shown in mm. 25.4mm = 1". Other shank sizes are also available

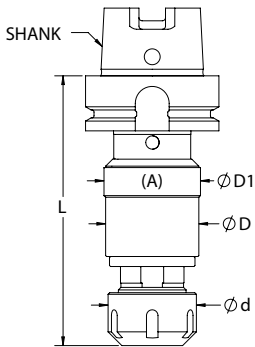

Adjusting Screws

Taps with External Center

Ø Tap Shank	SFT50II	SFT75II
6mm, 7mm	810836	
8mm, 9mm	810838	811838
10mm	8108310	8108310
11mm to 16mm		8118311

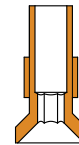

Taps with External Center

Taps with Internal Center

Ø Tap Shank	SFT50II	SFT75II
6mm, 7mm	810836IN	
8mm, 9mm	810838IN	811838IN
10mm	8108310IN	8108310IN
11mm to 16mm		8118311IN

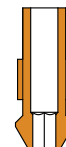

Taps with Internal Center

Additional sizes available on request.

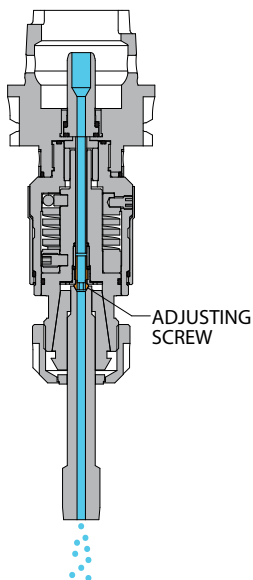



## Tension / Compression tap chucks for tapping cycles that are not synchronized

For tapping applications on CNC machines where the revolutions per minute and feed rate are not synchronized to the tap pitch, tap holders with tension / compression float are recommended. These tap chucks rely on the machine spindle for reversal, but by providing axial float, the tap is able to follow the correct pitch, producing gage perfect threads.

Tapmatic offers a complete program of tension / compression tap chucks with a wide range of sizes, and three different tap holding options. Rubberflex multi range collets, ER collets, or Quick Change.



### SM Rubberflex Collets

Tension / compression floating tap holders for gage perfect threads with releasable hard start for consistent tapping depth control.

For tap sizes M1.4-M30.

Only two collets needed to cover the capacity of each holder.



### SM ER Collets

All the same features as the rubberflex version but for use with ER square drive collets.

For tap sizes M1.4-M18.

ER GB square drive collets include an internal square drive for securely gripping the tap shank.



### TA Quick Change

In addition to tension/ compression and releasable hard start, the TA series includes front release. A safety feature that releases the quick change tap adapter when the extension float is exceeded.

For tap sizes M1-M49.

Quick Change for fast tap change without wrenches



### TIC Quick Change with Internal Coolant

All the same features as the TA series but with the addition of high pressure internal coolant up to 50 bar.

For tap sizes M3-M36.

## Tension/Compression tap chucks with straight shank or Morse taper and RF collet

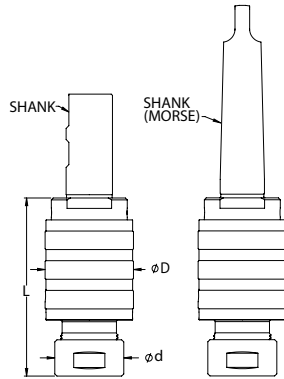

**Dimensions**

Model	D	d	L	Weight kg
SM2	27	19	53	0.2
SM4	38	27	71	0.4
SM6	48	37	96	0.8
SM8	63.5	57	128	2.5

Tapping chuck with increased tension and compression to accommodate tapping cycles that are not synchronized.

**Features and Advantages**

- increased tension and compression
- releasable hard start for consistent depth control
- right hand and left hand tapping
- multi-range collets (RF), adjustable back jaw for driving tap square

**How to Order**

Please select the tap chuck (A) and CAT, SK or BT shank (C), to fit your application. Please order rubber flex collets separately.

Model	Capacity (steel)	Collets Rubber Flex Order Code (Shank Ø)	Shank	Order code	Tension T	Compression H
SM2	M1.4–M7 #0 - 1/4"	21600 (2.5-4.5) 21700 (4.5-6.5)	16mm	023216	4.5	6
			5/8"	023262		
			No. 2 Morse	023202		
SM4	M3–M12 #6 - 1/2"	22100 (3.5-6.5) 22200 (6.5-10.0)	20mm	023420	7	7
			3/4"	023475		
			No. 2 Morse	023402		
SM6	M5–M18 #10 - 3/4"	24100 (4.5-10.0) 24500 (10.0-15.0)	25mm	023625	11	11
			1"	023610		
			No. 3 Morse	023603		
SM8	M10–M30 1/2" - 1 1/8"	26100 (10.0-16.0) 26200 (16.0-23.0)	32mm	023832	17	17
			1 1/2"	023815		
			No. 3 Morse	023803		
			No. 4 Morse	023804		

**Note:** Additional shanks available. When using roll form taps, the tool capacity must be reduced 25%.

## Tension/Compression tap chucks with modular straight shank and ER collet

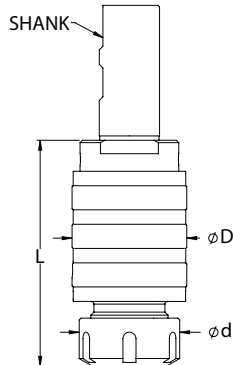

**Dimensions**

Model	D	d	L	Weight kg
SM2	27	28	65	0.2
SM4	38	34	74	0.4
SM6	48	42	94	0.8

Tapping chuck with increased tension and compression to accommodate tapping cycles that are not synchronized.

**Features and Advantages**

- increased tension and compression
- releasable hard start for consistent depth control
- right hand and left hand tapping
- ER steel collet chuck

**How to Order**

Please select the tap chuck (A) and CAT, SK or BT shank (C), to fit your application. Please order ER steel collets separately.

Model	Capacity (steel)	Collets	Shank	Order code	Tension T	Compression H
SM2	M1.4–M7 #0 - 1/4"	ER16	16mm	023216ER	4.5	5
			5/8"	023262ER		
SM4	M3–M12 #6 - 1/2"	ER20	20mm	023420ER	7	7
			3/4"	023475ER		
SM6	M5–M18 #10 - 3/4"	ER25	25mm	023625ER	11	11
			1"	023610ER		



## Tension/Compression tap chucks with modular straight shank and quick change

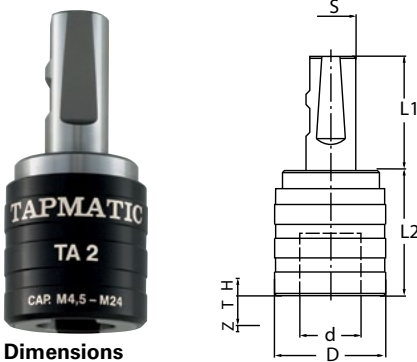

**Dimensions**

Model	D	d	L1	L2
TA0-016	29	13	48	38.0
TA0-020			50	
TA1-016	39	19	49	39.0
TA1-020			51	
TA1-025			57	
TA2-025	56	31	57	63.0
TA2-032				
TA3-032	81	48	61	124.0
TA4-040	99	60	71	135.5

TA tapping chuck with tension/compression. With its quick change spindle the taps can be changed in seconds.

**Features and Advantages**

- tension and compression
- releaseable hard start for consistent depth control
- front release protects against damage if over extended
- right hand and left hand tapping
- short projection

**How to Order**

Please order the tap chuck (A) and CAT, SK or BT shank (C) to fit your application. Please order tap adapters separately

Tension/Compression

(A) Model	Capacity (steel)	Adapter	Shank	Order code	Tension T	Compression H	Front release Z
TA0	M1-M10 #0 - 1/4"	Nr. 0	16 mm	490016	7.5	5	1.7
			20 mm	490020			
TA1	M3-M14 #8 - 9/16"	Nr. 1	16 mm	491016	8	5	2.1
			20 mm	491020			
			25 mm	491025			
TA2	M4.5-M24 5/16" - 7/8"	Nr. 2	25 mm	492025	15	8.5	2.8
			32 mm	492032			
TA3	M14-M36, 13/16" - 1 3/8"	Nr. 3	32 mm	493032	23.5	15	4.1
TA4	M22-M48, 7/8" - 1 7/8"	Nr. 4	40 mm	494040	25	16.5	5.7

**Note:** When using Roll Form Taps the chuck's tapping capacity must be reduced by 25 %.

## Tension/Compression tap chucks with morse taper and quick change

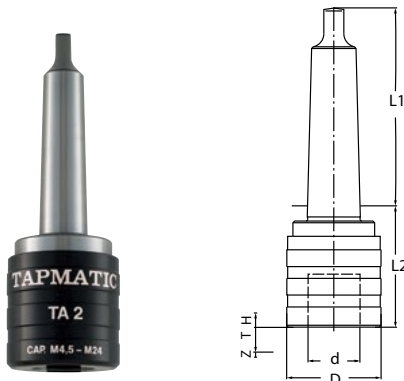

**Dimensions**

Model	D	d	L1	L2
TA0-MT1	29	13	62.0	43.5
TA0-MT2	29	13	75.0	45.0
TA1-MT2	39	19	75.0	47.0
TA2-MT3	56	31	94.0	71.0
TA3-MT4	81	48	117.5	105.0
TA4-MT5	99	60	149.5	116.5

**How to Order**

Please select the tap chuck (A) to fit your application. Please order quick change tap adapters separately.

(A) Model	Capacity (steel)	Tap adapters	Morse taper MT	Order code	Tension T	Compression H	Front release Z
TA0	M1-M10 #0-1/4"	Nr. 0	1	490MT1	7.5	5	1.7
			2	490MT2			
TA1	M3-M14 #8-9/16"	Nr. 1	2	491MT2	8	5	2.1
			3	491MT3			
TA2	M4.5-M24 5/16"-7/8"	Nr. 2	3	492MT3	15	8.5	2.8
			4	492MT4			
			5	492MT5			
TA3	M14-M36 13/16"-1 3/8"	Nr. 3	4	493MT4	23.5	15	4.1
			5	493MT5			
TA4	M22-M48 7/8"-1 7/8"	Nr. 4	5	494MT5	25	16.5	5.7
			6	494MT6			

**Note:** When using Roll Form Taps the chuck's tapping capacity must be reduced by 25 %. All dimensions are shown in mm. 25.4mm = 1"





Tension/Compression tap chucks with modular straight shank, quick change and internal coolant

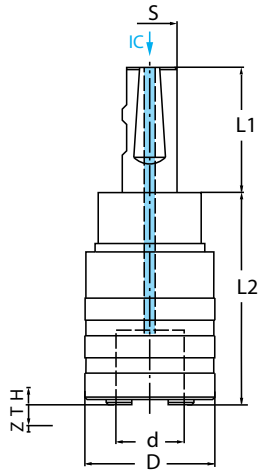

Tapping chuck with internal coolant system, tension, compression and quick-change spindle, where the tap can be changed in seconds.

Features and Advantages

- tension and compression
- releaseable hard start for consistent depth control
- front release protects against damage if over extended
- right hand and left hand tapping
- internal coolant system (max. 50 bar)
- short projection

How to Order

Please order the tap chuck (A) and CAT, SK or BT shank (C) to fit your application. Please order tap adapters separately.

Dimensions

Model	D mm	d mm	L1 mm	L2 mm
TIC1-025	43	19	57	62
TIC2-025	59	31	57	98
TIC3-032	80	48	61	147

(A) Model	Capacity (steel)	Adapter	Shank	Order code	Tension T	Compression H	Front release Z
TIC1	M3-M14, #8 - 9/16"	Nr. 1	25	49C1025	7.5	5	2.5
TIC2	M4.5-M24, 5/16" - 7/8"	Nr. 2	25	49C2025	10	7	3
TIC3	M14-M36, 13/16" - 1 3/8"	Nr. 3	32	49C3032	20	15	5

Note: When using Roll Form Taps the chuck's tapping capacity must be reduced by 25 %.

Tension/Compression tap chucks with HSK shank, quick change and internal coolant

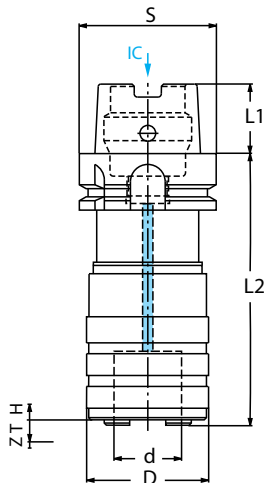

Dimensions

Model	D	d	L1	L2
TIC1-HSK50A	43	19	25	91
TIC1-HSK63A			32	93
TIC1-HSK80A			40	97
TIC1-HSK100A			50	98
TIC2-HSK50A	59	31	25	140
TIC2-HSK63A			32	130
TIC2-HSK80A			40	133
TIC2-HSK100A			50	135

How to Order

Please select the tap chuck (A) to fit your application. Please order quick change tap adapters separately.

(A) Model	Capacity (steel)	Adapter	Shank S HSK-A	Order code	Tension T	Compression H	Front release Z
TIC1	M3-M14 #8 - 9/16"	Nr. 1	50	49C1H50	7.5	5	2.5
			63	49C1H63			
			80	49C1H80			
			100	49C1H100			
TIC2	M4.5-M24 5/16" - 7/8"	Nr. 2	50	49C2H50	10	7	3
			63	49C2H63			
			80	49C2H80			
			100	49C2H100			

Note: When using Roll Form Taps the chuck's tapping capacity must be reduced by 25 %. All dimensions are shown in mm. 25.4mm = 1"



**Thread production on machining centers with constant speed tapping**



CNC-Attachments

**Two Through the Spindle Lubrication Options...**

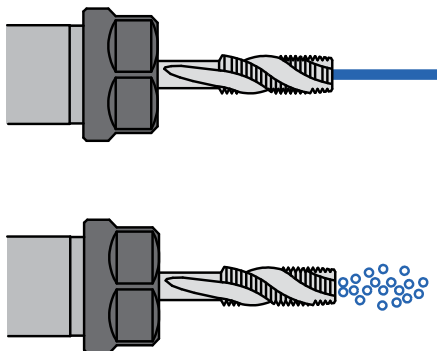

Standard balanced high pressure coolant through the spindle.

Minimum Quantity Lubrication, available on request.

CST Constant Speed Tapping relies on a compact tapping attachment to provide tap reversal. The machine spindle runs in one direction at the exact programmed speed and reversal occurs within the tapping attachment instantaneously upon machine retraction. This avoids the inevitable RPM fluctuations which occur with reversal of the machine spindle. Benefits include the following...

**Reduced Cycle Time**

By eliminating the machine spindles need to decelerate, stop, reverse and reaccelerate twice for each tapped hole the tapping time is dramatically reduced.

**Longer Tap Life, Improved Thread Quality**

Constant speed tapping means that the tap is allowed to cut at the optimum speed continuously without deceleration at the bottom of the hole. The result is the longest tap life and improved thread quality.

**Reduced Machine Spindle Wear**

Tapping is the only operation requiring machine reversal. Using a Constant Speed Tapping Head eliminates this strain on the machine.

**Reduced Energy Costs of up to 75 %**

CST attachments reduce the energy costs required by machine spindle reversal by 75 %.

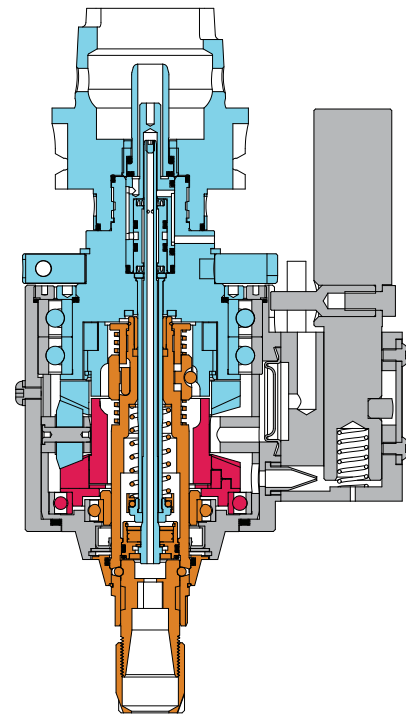

**Patented Design**

TAPMATIC tapping attachments include a patented reversing ball drive. The ball drive allows for an exact and immediate change over into reverse once the desired thread depth is reached.

## Advantages of tapping attachments with automatic reversal

### General Information

Thread cutting is the only machining operation which requires a change of direction for the retraction of the tool. Reversing the spindle causes wear and is a costly procedure for any machine.

### RCT and RDT tapping attachments

These reversing tapping attachments are specially designed for fast thread production on CNC machining centers. They eliminate reversal related machine wear and tear and reduce energy consumption. The patented ball drive with integrated planet gear for automatic reversal creates an almost constant cutting speed and eliminates the need to stop and reverse the machine spindle twice per tapped hole.

By using the RDT and RCT tapping attachments the cycle time is reduced and the life of the tap is increased. The IC-version allows coolant to flow directly through the tapping head.

### Case history:

#### Original Application

Thread cutting on a horizontal machining center Fritz Werner TC800 with internal coolant.

#### Material

GG20

#### Tap

M6 standard thread HSS with TIN-AL coating

#### Thread

M6 standard thread, 9 mm deep, tapping drill  $\varnothing$  5.05 and 12.5 mm deep

#### Speed with machine reversal

Rigid tapping with spindle reversal, programmed speed 1,200 RPM

#### Original Results

Cycle time of 6 min 34 sec for 68 threads

#### Change with TAPMATIC

Using a TAPMATIC tapping attachment RDT-IC50 with ER16 spindle, programmed speed 1,800 RPM.

#### Improvement

Cycle time reduced to 3 min 22 sec for 68 threads, tap life tripled.

#### Advantage

Besides reducing the cycle time, tap life was considerably increased.

### Constant speed tapping – the secret of longer tap life

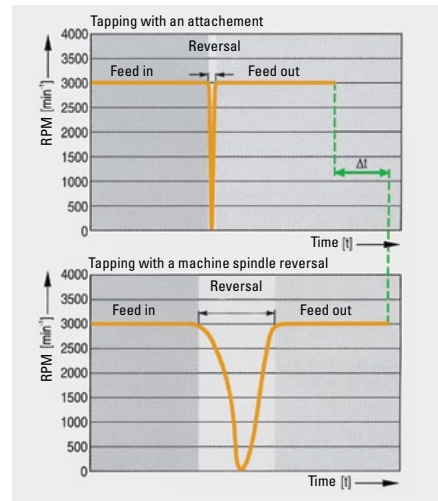

### Power consumption for 144 threads M8

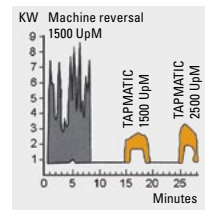

Energy cost saving of 75 %

Not only is the shorter cycle time of importance, but also the constant spindle direction. By changing the direction (decelerating and accelerating) of the spindle, higher spikes of power are needed, which can be prevented by constant spindle rotation.

### Total cost/year

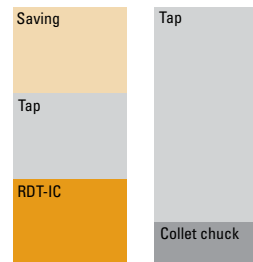

### Break Even Point

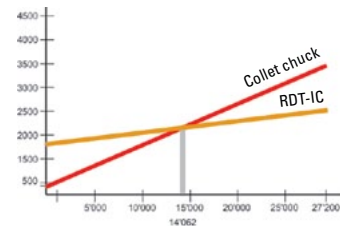

### Results

- reduction of cycle time by 50 %
- increase of production capacity
- tap life tripled
- less machine wear (no spindle reversals)
- roughly 75% energy savings by constant speed tapping

### Conclusion

With the use of Tapmatic constant speed tapping, the cycle time is less, which increases productivity. Additionally, machine repair / downtime and energy costs are reduced and tap life is dramatically improved.

**High speed tapping attachments with modular straight shank, without internal coolant system**

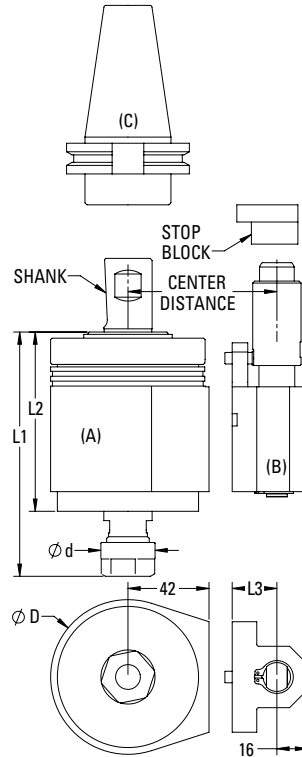

**Features and Advantages**

- high speed self-reversing tapping for fastest cycle time for tap capacity up to M6
- rugged design for years of production, with little maintenance
- simple installation and programming

**How to Order**

Please select the Tapping attachment (A), stop arm (B) and CAT, SK, or BT shank (C), to fit your machine. Accessories like steel collets, sealing gaskets and stop blocks are not included. Please order these separately.

Tapmatic can provide a complete tool ready to fit your machine. Please simply provide the information shown on installation page 23, fill in the form on the back cover or contact us directly.



**(A) Tapping Attachment RDT Cylindrical Shank**

Model	Capacity (steel)	Collets	Shank	Order code	L1	L2	Weight kg	D	d	Max. RPM
RDT25	M2-M6 #4-1/4"	ER11	25 mm	39252511	106	79	1.7	57	19	4000
			1"	39251111						

**Notes:** When using Roll Form Taps the tool's capacity must be reduced 25%. All dimensions are shown in mm. 25.4mm = 1"



**(B) Stop Arm Assembly**

Center Distance (42+L3)	Order code RDT25	L3
55	3925551	13
65	3925651	23
80	3925801	38



**Stop Block**  
Page 23



Interchangeable Steep Taper



Steel Collets



Installation

# High speed tapping attachments with modular straight shank and internal coolant system or without internal coolant

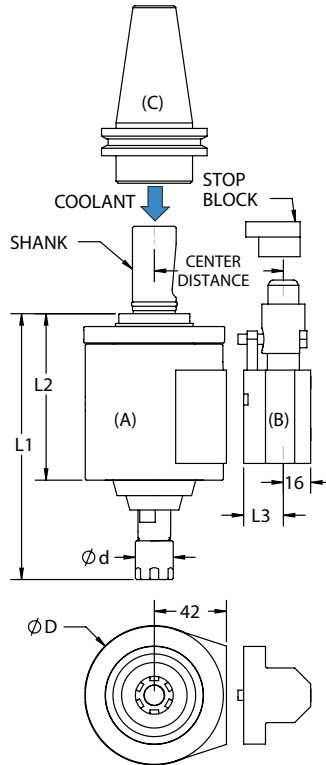

### Features and Advantages

- high speed self-reversing tapping for fastest cycle time
- rugged design for years of production, with little maintenance
- high pressure internal coolant system, 50 Bar
- simple installation and programming

### How to Order

Please select the Tapping attachment (A) and stop arm (B) and CAT, SK or BT shank (C) to fit your machine. Accessories like steel collets, sealing gaskets and stop blocks are not included. Please order these separately.

Tapmatic can provide a complete tool ready to fit your machine. Please simply provide the information shown on installation page 23, fill in the form on the back cover or contact us directly.

### (A) Tapping Attachment RCT Cylindrical Shank with Internal Coolant (IC)



Model	Capacity (steel)	Collets	Shank	Order code	L1	L2	Weight kg	D	d	Max. RPM
RCT50	M4.5–M12 #10–1/2"	ER16	25 mm	05502516	155	97	3.0	80	22	2500
			1"	0550116						
		ER20	25 mm	05502520	167	97	3.0	80	28	2300
			1"	0550120						

### (A) Tapping Attachment RCT Cylindrical Shank without Internal Coolant

Model	Capacity (steel)	Collets	Shank	Order code	L1	L2	Weight kg	D	d	Max. RPM
RCT50	M4.5–M12 #10–1/2"	ER16	25 mm	04502516	152	97	3.0	80	22	2500
			1"	0450116						
		ER20	25 mm	04502520	162	97	3.0	80	28	2300
			1"	0450120	162	97				

**Notes:** When using Roll Form Taps the tool's capacity must be reduced 25%. All dimensions are shown in mm. 25.4mm = 1". Larger capacity tapping attachments up to M27, and extended length versions for difficult to reach holes, are also available on request.

### (B) Stop Arm Assembly



Center Distance (42+L3)	Order code RCT50	L3
55	0550551	13
65	0550651	23
80	0550801	38



Stop Block  
Page 23





# High speed tapping attachments with integral HSK shank and internal coolant system

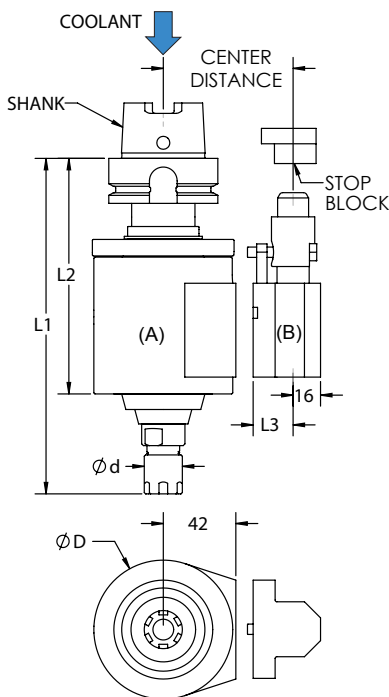

### Features and Advantages

- high speed self-reversing tapping for fastest cycle time
- rugged design for years of production, with little maintenance
- high pressure internal coolant system, 50 Bar
- simple installation and programming

### How to Order

Please select the Tapping attachment (A) and stop arm (B) to fit your machine. Accessories like steel collets, sealing gaskets and stop blocks are not included. Please order these separately.

Tapmatic can provide a complete tool ready to fit your machine. Please simply provide the information shown on installation page 23, fill in the form on the back cover or contact us directly.

CNC-Attachments

### (A) Tapping Attachment RCT HSK with Internal Coolant (IC)



Model	Capacity (steel)	Collets	Shank	Order code	L1	L2	Weight kg	D	d	Max. RPM
RCT50	M4.5–M12 #10–1/2"	ER16	HSK63A	0550H63161	194	136	3.5	80	22	2500
			HSK80A	0550H80161	199	141	3.9			
			HSK100A	0550H100161	201	143	4.8			
ER20	HSK63A	0550H63201	206	136	3.5	80	28	2300		
		HSK80A	0550H80201	211	141				3.9	
		HSK100A	0550H100201	213	143				4.8	

**Notes:** These internal coolant tools come standard with sealing nuts. These models are also available without internal coolant upon request. When using Roll Form Taps the tool's capacity must be reduced 25%. All dimensions are shown in mm. 25.4mm = 1"

Larger capacity tapping attachments up to M27, and extended length versions for difficult to reach holes, are also available on request.

### (B) Stop Arm Assembly



Center Distance (42+L3)	Order code RCT50	L3
55	0550551	13
65	0550651	23
80	0550801	38



**Stop Block**  
Page 23



Steel Collets



Sealing Gaskets



Installation



**Tapmatic can supply a tapping attachment ready to fit your machining center**

RDT and RCT tapping attachments eliminate the need for the machine spindle to reverse by automatically reversing the taps rotation when the machine retracts. For the automatic reversal to function a stop arm is needed to prevent the housing of the tapping attachment from rotating. Our stop arm locking mechanism allows the tool to easily make automatic tool changes.

**Tapmatic maintains a large data base of machining center installations**

Please simply let us know the machine manufacturer, make and model and we may already have the installation information available to provide a tool ready to run on your machine.

**My machine already has a stop block**

If your machine already has an anti-rotation stop block installed, please let us know the dimensions shown in the drawing below. We can prepare a tool to go with your existing stop block.

**My machine does not have a stop block**

If your machine does not have a stop block already installed, we would be pleased to prepare one for you. Please simply fill in the form on the inside back cover or download it from our website under "Customer Service", and forward us the information. We will be pleased to submit an offer to you.

**Preferred Installation**

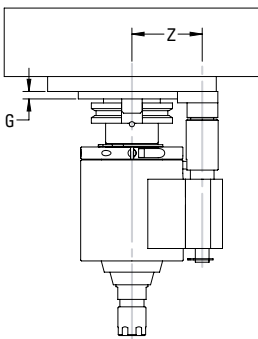

Gage Line to Mounting Surface

G =

Center Distance

(commonly 55, 65, or 80)

Z =

Diameter of Bore or Width of Slot in Stop Block

D =

Depth of Bore or Slot in Stop Block

E =

Total Height of Stop Block

F =

Machine Spindle Taper (SK, BT, CAT, HSK...)

Shank =

Machine Manufacturer and Model =

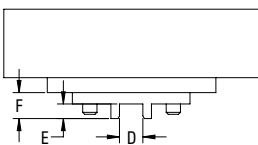

**Standard stop blocks are available if you would like to design your own installation.** These blank stop blocks can be modified to fit the bolt pattern of your machine.

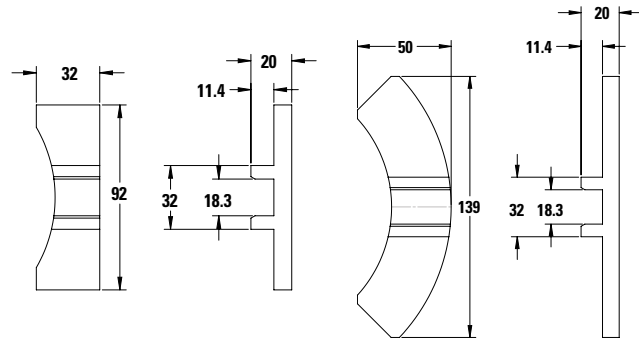

**Order code.**  
36007 Standard Block

**Order code**  
36010 Standard Block

Tapping attachments for manual tapping applications



**Drill-n-Tap**  
For drilling and tapping with quick change spindle.

**Tapping attachments for drilling and milling machines and pneumatic, hydraulic and electric spindles**

Since 1952 Tapmatic has manufactured the world's most popular line of compact self-reversing tapping attachments. Our experience and commitment to quality make these tools an excellent value. Although there are other products available on the market, a Tapmatic head is still the most economical to use. Our customers know they can count on our tools for many, many years of service.

Tapmatic offers a complete program of self-reversing tapping attachments to meet the most difficult requirements. Ruggedly built, these Tapmatic tools provide higher production rates due to:

- decrease in tap breakage
- production of perfect threads
- reduced cycle time through increased 1.75:1 reverse speed
- longer tap life
- accurate depth control
- better thread quality
- consistent trouble free performance
- interchangeable mounts
- left hand versions available on request

**RX II**  
Newest series for high production with heavy duty ball clutch.



**Self-reversing tapping attachment for drilling and tapping with high-speed reverse, pre-selective torque control and quick change**

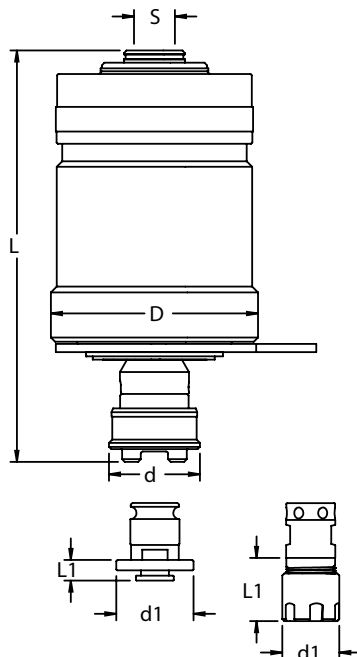

- for tapping and drilling
- great for combination drill-tap cutting tools.
- unique design for improved concentricity
- quick change for rapidly changing the cutting tool
- reduced cycle time when tapping thanks to 1.75 to 1 reverse speed
- less tap breakage due to pre-selective torque control
- adjustable self-feed and hard start for accurate depth control

**How to Order**

Please select the tapping attachment (A) and arbor (C) to fit your application. Choose an arbor to fit the thread or taper mount of the tapping attachment, with Morse Taper, R8 or straight shank to fit your machine. Please order quick change adapters and collets separately. Please order torque bars separately.

**Dimensions**

Model	D mm	d mm	Self-feed mm T	Weight kg
Drill-n-Tap 50	80	35	2-5	2.0

Model	Tap Capacity (steel)	Adapter Size	Mount S (Internal Taper or Thread)	Order code	L	Max. RPM
Drill-n-Tap 50	M3-M12 #6 - 1/2"	NR. 1	#6 Jacobs Taper	016006	159	1500
			DIN B16 Taper	016016		
			#33 Jacobs Taper	016033		
			7/8"-20 Thread	016087	154	

**Note:** When using Roll Form Taps the tool's capacity must be reduced by 25%. All dimensions are shown in mm. 25.4mm = 1".



Description	d1	L1
Nr. 1, P Type Tap Adapters	30	7



Order code	Adapter size	Collets Used	Clamping Ø	d1	L1
8208216	Nr. 1	ER16 (Mini nut)	2.5-10	22	24-27
8218220		ER20 (Mini nut)	2.5-13	28	35-38
8118220N		ER20 (Standard nut)	2.5-13	34	35-38

For tapping, the P type tap adapters may be used. Please order separately by tap size. See Pages 40-41.

The ER16 and ER20 quick change adapters use ER collets. They can be used together with ERGB (square drive collets) for tapping and with standard collets for holding center drills and drills. Please order separately.

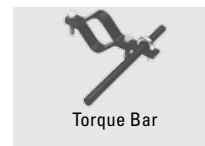
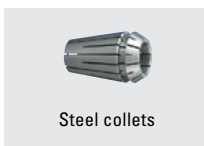

# High production self-reversing tapping attachments with high-speed reverse and pre-selective torque control

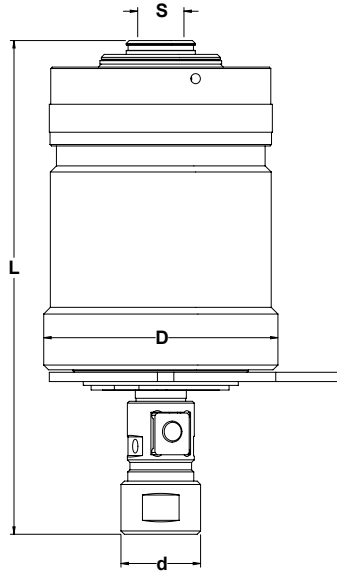

- for high production tapping on drill press, and milling machines.
- unique design for improved concentricity.
- Rubber Flex collet spindle.  
Only two collets required to cover the full tap capacity.
- reduced cycle time thanks to 1.75 to 1 reverse speed
- less tap breakage due to pre-selective torque control with heavy duty ball clutch
- easy adaptation with multiple interchangeable arbors

**How to Order**

Please select the tapping attachment (A) and arbor (C) to fit your application. Choose an arbor to fit the thread or taper mount of the tapping attachment, with Morse Taper, R8 or straight shank to fit your machine. Please order rubber flex collets and torque bars separately.

**Dimensions**

Model	D	d	Self-feed	Weight kg
Rx II 30	53	19	3	0.8
Rx II 50	80	27	5	2.0
Rx II 70	88	37	7	3.0

(A) Model	Capacity (steel)	Collets Rubber Flex Order Code (Shank Ø)	Mount S (Internal Taper or Thread)	Order code	L	Max. RPM
Rx II 30	M1.4-M7 #0 - 1/4"	21600 (2.5-4.5) 21700 (4.5-6.5)	#6 Jacobs Taper	<b>11406</b>	116	2000
			DIN B16 Taper	<b>11416</b>		
			#33 Jacobs Taper	<b>11433</b>		
			1/2"-20 Thread	<b>11450</b>		
Rx II 50	M3-M12 #6 - 1/2"	22100 (3.5-6.5) 22200 (6.5-10.0)	#6 Jacobs Taper	<b>116006</b>	169	1500
			DIN B16 Taper	<b>116016</b>		
			#33 Jacobs Taper	<b>116033</b>		
			7/8"-20 Thread	<b>116087</b>		
Rx II 70	M5-M18 #10 - 3/4"	24100 (4.5-10) 24500 (9.0-15.0)	#3 Jacobs Taper	<b>11803</b>	164	1200
			7/8"-20 Thread	<b>11887</b>	182	

**Note:** When using Roll Form Taps the tool's capacity must be reduced by 25%. All dimensions are shown in mm. 25.4mm = 1".

**RF Rubber Flex Collets**

Tapping Head Capacity	RF Collet Order code	Clamping Capacity (mm)	Tap Capacity Metric Sizes (DIN 371, 374)	Tap Capacity Inch Sizes
M1.4-M7 #0-1/4"	<b>21600</b>	2.5-4.5	M1.6-M4	#0-#8
	<b>21700</b>	4.5-6.5	M4-M6	#10-1/4"
M3-M12 #6-1/2"	<b>22100</b>	3.5-6.5	M3-M6	#0-1/4"
	<b>22200</b>	6.5-10.0	M7-M12	5/16"-1/2"
M5-M18 #10-3/4"	<b>24100</b>	4.5-10	M4-M12	#10-1/2"
	<b>24500</b>	9.0-15.0	M10-M18	1/2"-3/4"



RF Multi-range Collets



Arbors



Torque Bar



**Large capacity self-reversing tapping attachment for high production with pre-selective torque control**

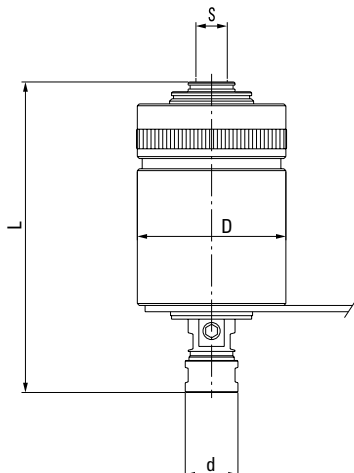

- less tap breakage due to pre-selective torque control
- easy adaptation with multiple interchangeable arbors
- reduced cycle time through increased 1.75:1 reverse speed
- only 2 Rubber Flex collets per model required.

**How to Order**

Please select the tapping attachment (A) and arbor (C) to fit your application. Choose an arbor to fit the thread or taper mount of the tapping attachment, with the Morse Taper, R8 or straight shank to fit your machine. Please order rubber flex collets and torque bars separately .

**Dimensions**

Model	D	d	Self-feed	Weight kg
90X	105	57	13	5.0

(A) Model	Capacity (steel)	Collets Rubber Flex Order Code (Shank Ø)	Mount S (Internal Taper or Thread)	Order code	L	Max. RPM
90X	M10-M30	26100 (10.0-16.0)	#4 Jacobs Taper	10904	219	600
	1/2" - 1 1/8"	26200 (16.0-23.0)	1 1/2"-18 Thread	10915		

**Note:** When using Roll Form Taps the tool's tapping capacity must be reduced by 25%.

\* All dimensions are shown in mm. 25.4mm = 1"

**RF Rubber Flex Collets**

Tapping Head Capacity	RF Collet Order code	Clamping Capacity (mm)	Tap Capacity Metric Sizes (DIN 371, 374)	Tap Capacity Inch Sizes
M10-M30	26100	10.0-16.0	M10, M14-M20	9/16"-3/4"
1/2"-1 1/8"	26200	16.0-23.0	M20-M30	13/16"-1 1/8"

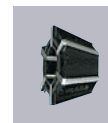



We're not just tapping! Our Effectivity Tools line includes three options for CNC marking: dot-peen, scribing and stamping...

and the new DeBurr-Z for deburring on your CNC!



The TapWriter for dot-peen marking

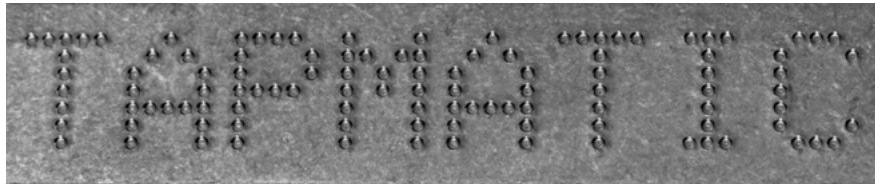
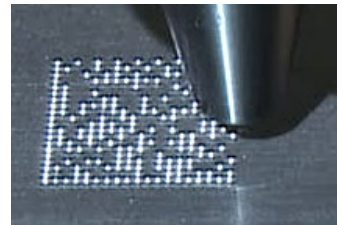

The ScribeWriter Force II for scribing





The MH Marking Heads for stamping



The new DeBurr-Z axial floating tool for deburring on CNC machines



## Dot Peen Marking tool for CNC marking

### The TAPMATIC TapWriter



- Eliminates extra operations
- Faster than engraving
- Long tool life with replaceable carbide stylus
- Mark hard or soft materials
- Mark round or uneven surfaces
- Simple to install and program

The TapWriter allows you to mark your work piece while you are machining it without the need for a secondary marking operation. Part numbers, date codes, logos and even decorative patterns and artwork can easily be created with this unique dot marking tool.

Installs easily on Machining Centers or CNC lathes with Live Tooling.

It utilizes standard engraving software, but unlike engraving, dot-peen marking does not require the use of delicate cutting tools and high speed spindles.

You can mark soft plastics or steel as hard as 55 RC.

The durable carbide stylus is thrown against the work piece which allows the marking of uneven or round surfaces.

The TapWriter is Fast. Up to 80 characters per minute or more just depending on the capabilities of your machine.

Dot peen marking is widely used in the aerospace industry because the cross section of the dot has gentle curves, resulting in no significant stress concentration.

With the TapWriter you have complete control of the mark. The revolutions per minute determines the dots per minute, and the velocity of the carbide stylus when it impacts the work piece. The feed rate controls the distance between dots allowing you to select the appearance of discrete dots or a continuous line.

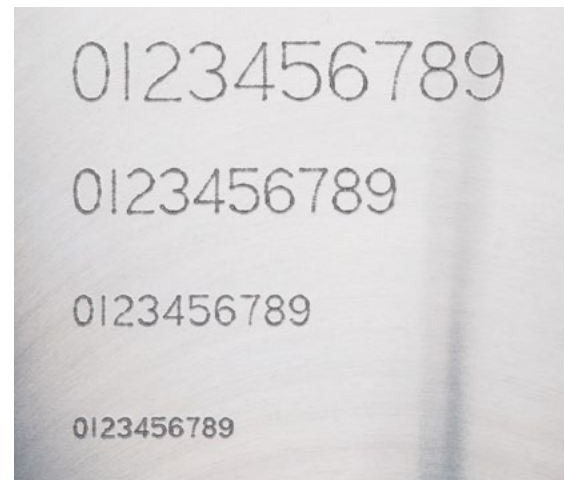

**Character heights shown from 6 mm to 2 mm, using standard engraving software.**



**Point to point programming for creating characters with defined dot position or 2D Data Matrix codes.**



**How to Order**

The TapWriter® adapts to machining centers with automatic change, using a locking stop arm, similar to those used with self reversing tapping attachments. Please select the TapWriter® (A), stop arm (B), and CAT, SK, or BT shank (C), to fit your machine. Please order accessories separately.

**TapWriter® with Stop Arm Bar and Stop Block Installation**

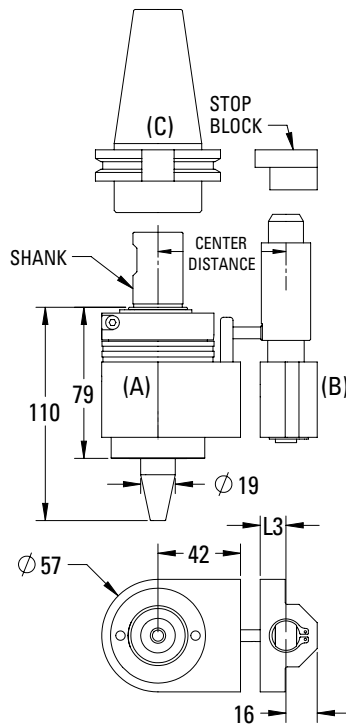

**(A) TapWriter® CNC Dot Peen Marking Tool**

Model	Order code	Shank	Weight kg
TAPWRITER	57820	20 mm	1.7
	57825	25 mm	
	57810	1"	

**(B) Stop Arm Assembly**

Center Distance (42+L3)	Order code	L3
55	3925551	13
65	3925651	23
80	3925801	38

Special stylus points or extended lengths are available on request.





# ScribeWriter® Force II

Marking tool for work piece scribing



With high pressure internal coolant



## Mark It While You Make It.

- Scribing tool for CNC machines.
- For marking of different materials up to 62 HRC hardness, and surface variations up to 5mm.
- Fast marking without spindle rotation.
- Simple programming directly at the machine control or from the programmers work station using engraving software.
- Marking force and resulting depth are adjustable by turning the knurled sleeve.
- Easy to read marking force reference scale with high quality magnification lens from Thorlabs.
- Settings 0-7 for gradually increasing force up to setting H for marking the hardest materials. There is no need to change springs.
- With high pressure internal coolant capability for improved stylus lubrication and increased marking force.
- Simple to change, long life, carbide stylus. A 90° and 60° stylus are available.
- New ball point stylus option. The rolling ball creates very smooth lines, but depth is shallower in comparison to scribing points.

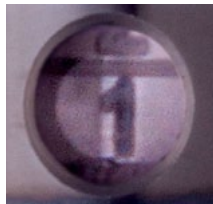

Marking force reference scale.

Turn to increase or decrease marking force.

Easy to exchange long life carbide stylus.

## Setting 0-7 for marking all kinds of materials

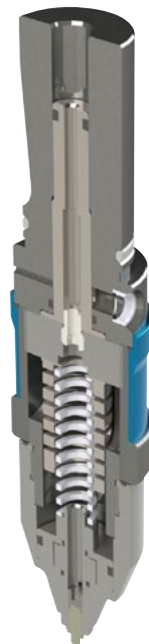

## Setting H for hard materials



Unique flexure technology for higher marking force without the need to change springs.

# ScribeWriter® Force II

Marking tool for work piece scribing



Example in 4140 pre heat treated material with hardness 28 HRC. Marking at different settings with 1.3 mm compression against the surface.



Example created with new ball point stylus in aluminum material.



Example marking a curved surface programmed at constant marking plane. Material is S7 tool steel heat treated to 60 HRC. Setting 'H' with 2mm compression at closest point on surface.

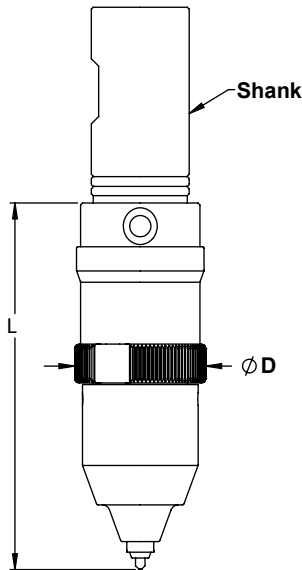

### How to Order

Please select the ScribeWriter® with shank to fit your application. Please order CAT, SK, or BT shanks separately. The ScribeWriter® comes with one standard 90° stylus. A 60° stylus is also available.

Order code	Shank	L	Ø D
57601	1"	95	32
57625	25 mm	95	32
57620	20 mm	95	32
57616	16 mm	95	32

**Note:** To order the ScribeWriter with 60° stylus, please specify by adding "-60" to the above order codes. To order the ScribeWriter with a ball point stylus please specify by adding "-B" to the above order codes.

### Standard Stylus Options

Order code	Stylus Point
7361608	90°
7361611	60°



### Changing the stylus

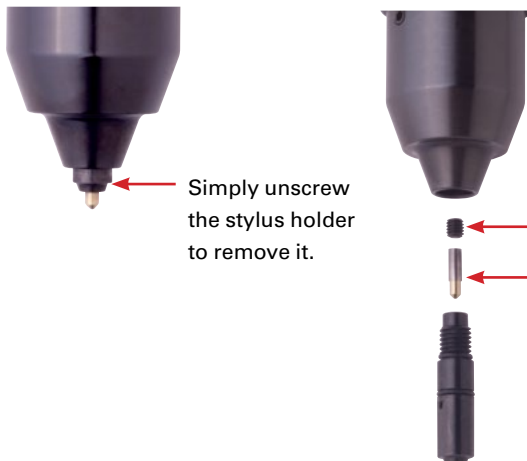

Simply unscrew the stylus holder to remove it.

Remove the retaining screw.

The stylus can then be removed and changed.

### Ball Point Stylus Options

Order code	Description
73602BN4A	Complete ball point assembly
71735C	2mm carbide ball



## CNC Marking Heads for use with standard type or custom stamps

### Tapmatic MH Series Marking Heads



**Eliminate the need for expensive secondary marking operations.** The Marking Head allows you to mark the work piece during the machining process.

**Simple to install on Machining Centers, CNC lathes or even manually controlled conventional machines.** Compact in size, they fit easily in the tool magazine or turret without interference.

**With the Marking Head, no rotation is required.** Simply advance the head against the work piece a short distance to charge the internal impact system and rapid feed away.

**The impact force and marking depth can be adjusted by turning the knurled sleeve.**

**The Marking Heads shock absorption system cushions any recoil effect on the machine spindle or turret.**

**With the Marking Head you can hold standard type or custom made stamps.** Mark part numbers, date codes, batch codes, logos or other information.

**The marking location and depth are accurate and consistent.**

**Characters and stamps are securely held and can be changed quickly.**

**The Marking Head is fast.** Stamping the work piece takes less than one second.



CNC Marking Heads for use with standard type or custom stamps

How to Order

Please select the Marking Head with the shank to fit your application. Please order accessories like standard type or custom stamps separately. Please note the Marking Head accepts standard type directly or you can use one of the separate Type Holders for quick replacement of characters and fast change over.

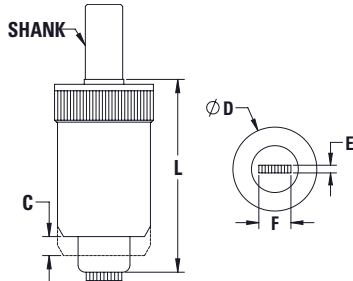

MH Marking Heads with Type Holder

Model	Order code	Shank	E	F	D	L	Stroke C	Weight kg
MH 1/2	575020TH	20 mm	6.4	24.5	62	128	12	1.6
	575025TH	25 mm						
	575075TH	3/4"						
	575010TH	1"						
	575003TH	No.3 Morse						
MH 3/4	577525TH	25mm	6.4	40	86	172	18	3.4
	577510TH	1"						

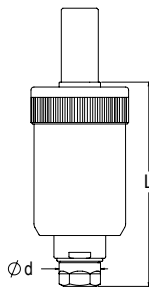

MH Marking Heads with ER Collet Holder

Model	Order code	Shank	Collets	D	d	L	Stroke C	Weight kg
MH 1/2	57502016	20 mm	ER16	62	28	138	12	1.6
	57502516	25 mm						
	57507516	3/4"						
	57501016	1"						
MH 3/4	57752525	25mm	ER25	86	42	190	18	3.4
	57751025	1"						

**Note:** The impact force of each marking head may be adjusted by turning its knurled sleeve. For softer materials like plastic we also have the ability to deliver a Marking Head with lighter springs. Spring sets for greater force are also available. Please just let us know the details about your specific application for a recommendation.

Standard Type Dimensions

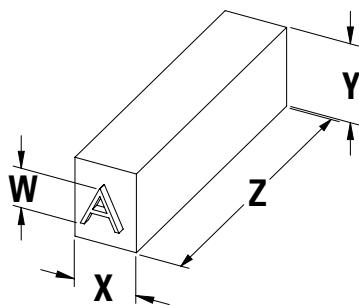

W	X	Y	Z	Order code 26 Letters	Order code 10 Numbers	Order code Blank Spacer
1	1.6	6.4	22.2	5707111006	5707101000	5707014002
1.5	1.6	6.4	22.2	5707112009	5707102003	5707014002
2	2	6.4	22.2	5707113001	5707103006	5707015005
2.5	2.4	6.4	22.2	5707114004	5707104009	5707016008
3	3.2	6.4	22.2	5707115007	5707105001	5707017000
4	4	6.4	22.2	5707120001	5707118008	5707021008
5	4.8	6.4	22.2	5707117002	5707106004	5707018003
6	6.5	9.5	19	5707950 *	5707951 *	5707952 *

**Note:** To order individual letters or numbers please use the set order code shown above followed by the desired character.  
 FOR EXAMPLE: "5707111006D" for the letter D character with height of 1mm.  
 \* Only for use with type holder 5775THILG

Type Holders for fast change over

Model	Order code	A	B	C	D
MH 1/2	5750THI	24	6.35	6.4	24
MH 3/4	5775THI	40	6.35	6.4	40
MH 3/4	5775THILG	40	6.35	9.6	40

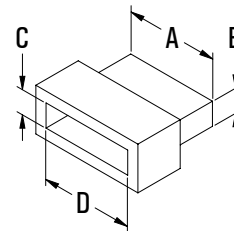

Custom Stamps Available on Request

**Note:** Tapmatic can also supply custom stamps to fit the Marking Heads. Please let us know the details of your application and we will be pleased to provide a proposal drawing and quote.





***NEW!*** **DeBurr-Z**  
**CNC Deburring Tool**  
**with**  
**Compression and Extension Float**

- Deburr parts quickly and consistently on the CNC machine eliminating the need for tedious hand work.
- The DeBurr-Z floats in both compression and extension allowing the cutting tool to follow the top edges or underside edges of the work piece, even when these are not clearly defined like in the case of castings and cross holes.
- Adjust the force by turning the knurled sleeve. Increase or decrease the pressure depending on the type of material and desired edge break. There is no need to disassemble or change springs.
- A wide range of burr cutting tools are available to suit your particular application.
- Also recommended for engraving. The compression float allows a faster approach to the work piece, and marking on curved surfaces.



CNC axial floating tool holder for deburring and chamfering. Here are a few example applications.

**Deburring Top Edges**



**Underside Edges**

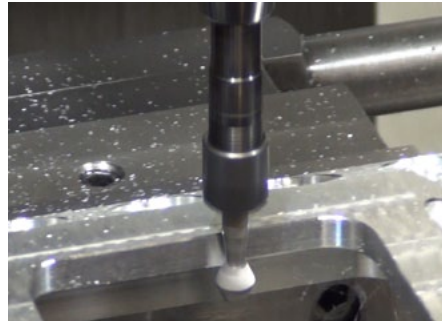

**Intersecting Edges**

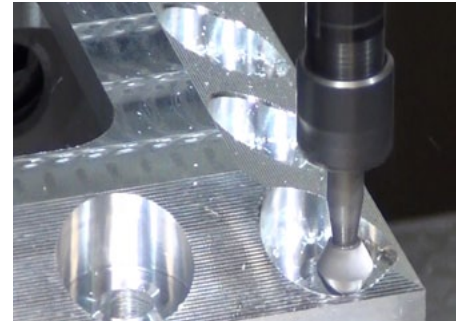

**Chamfering holes on a curved surface presents a problem for conventional methods.**

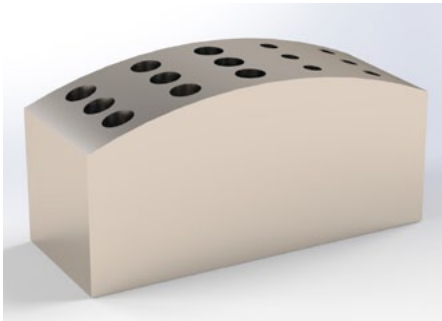

**Using a standard countersink tool results in inconsistent edge breaks.**



**Going around the holes with the axially floating DeBurr-Z produces consistent results.**



**The DeBurr-Z can also be used for engraving. It allows a faster approach to the work piece and the ability to mark on curved surfaces. We offer combination deburring/engraving cutting tools.**

## CNC tool holder for deburring and chamfering

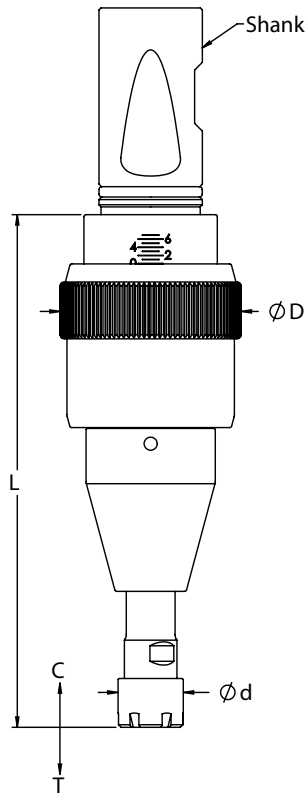

- for deburring, and chamfering on CNC machines.
- floats in compression and extension for deburring the topside or underside edges of the work piece.
- the floating holder allows the cutting tool to follow the edges of the work piece even when these are not clearly defined like in the case of castings or cross holes.
- improves the life of cutting tools thanks to the adjustable compression force.
- speeds up the process by allowing faster approach feed rates.
- the compression and extension force can be simultaneously and equally adjusted for increasing or decreasing the pressure of the cutting tool against the work piece.
- ER11 collet holds a wide variety of burr cutting tools.
- easy programming and installation on the CNC machine.

### How to Order

Please select the DeBurr-Z (A) and shank (B) to fit your application. Please order ER11 collets and burs separately.

(A) Model	Order code	Shank	Collets (Capacity)	Max. RPM	Compression C	Extension T	d	D	L	Weight kg
DeBurr-Z	57301	1"	ER11 (2.5-6.5)	10,000	10	10	16	44	128	0.7
	57320	20 mm								
	57325	25 mm								

**Note:** All dimensions are shown in mm. 25.4mm = 1"

The above tools all include shanks with weldon flats. We do also offer a 20mm shank without flats, please use Order code 57320CY.

We also offer kits for each of the above tools that include the DeBurr-Z, collet for 6.4mm, and one 12.7mm universal ball shape bur. To specify please add 'K' to the end of the above Order codes.



Interchangeable Steep tapers



ER11 Collets

## Bur Cutting Tools for use with the DeBurr-Z

We recommend spherical and angular shaped burs. These are available in a variety of sizes, shapes and tooth patterns, from different manufacturers. Below are examples of some of the burs we offer. These are all carbide tools which can be used for a variety of work piece materials including steel, aluminum and cast iron. Please let us know if your application requires a different size or shape. We would be pleased to help.

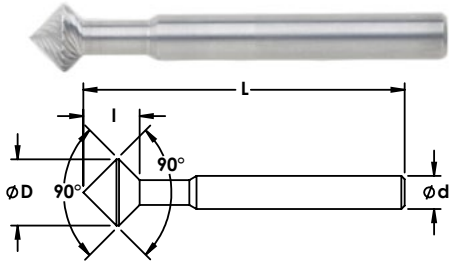

### Top edge and underside edge deburring and engraving.

Order code	D	d	L	l
52MM20590W	9.5 (3/8")	6.4	58.5	17
52MM20591W	12.7 (1/2")	6.4	61.5	20

### Top edge and underside edge deburring.

52SKN6W	15.9 (5/8")	6.4	60.2	15
---------	-------------	-----	------	----

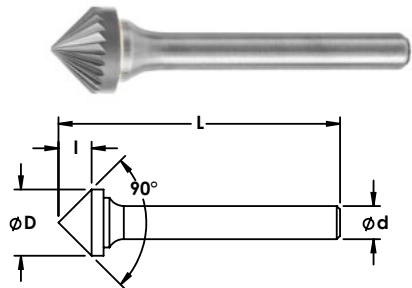

### Top edge deburring

Order code	D	d	L	l
52SK3W	9.5 (3/8")	6.4	52.4	4.8
52SK5W	12.7 (1/2")	6.4	54.0	6.4

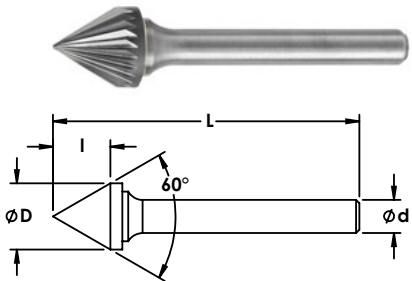

### Top edge deburring.

Order code	D	d	L	l
52SJ3W	9.5 (3/8")	6.4	54.0	8.0
52SJ5W	12.7 (1/2")	6.4	58.7	11.0

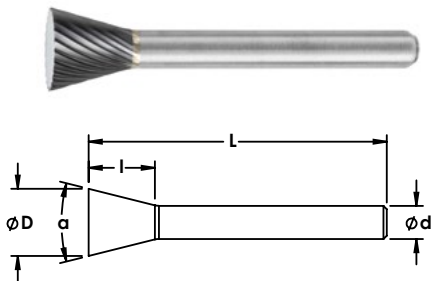

### Underside edge deburring.

Order code	D	d	L	l	a
52SN5W	12.7 (1/2")	6.4	57.0	12.7	28°

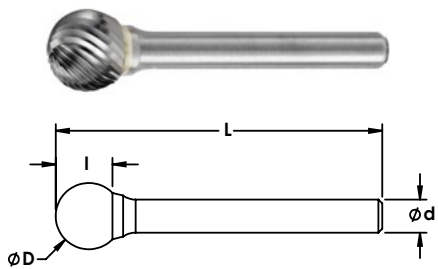

### Top edge and underside edge deburring.

Order code	D	d	L	l
52SD2W	6.4 (1/4")	3.2	44.5	5.5
52SD3W	9.5 (3/8")	6.4	52.4	8.0
52SD3WL6	9.5 (3/8")	6.4	160.4	8.0
52SD5W	12.7 (1/2")	6.4	54.0	11.0
52SD5WL6	12.7 (1/2")	6.4	163.5	11.0
52SD6W	15.9 (5/8")	6.4	57.0	14.3
52SD7W	19.0 (3/4")	6.4	63.5	17.5

## Quick-change adapters, positive drive *inch sizes*

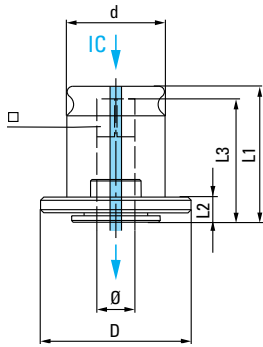

For quick change tap chucks TA, TIC, NC and SPD QC, with or without internal coolant system.

### Features and Advantages

- equally appropriate for taps with internal coolant
- no pre-selective torque drive
- suitable for right and left hand tapping

Model	Adapter Size	Dimensions			
		d mm	L1 mm	D mm	L2 mm
P0	0	13	26.5	22	7
P1	1	19	28.5	30	7
P2	2	31	46.5	48	11
P3	3	48	68.5	70	14
P4	4	60	105.0	92	42

### Product range – Adapters

Tap	Shank Ø inch	Square inch	Order code P0	Order code P1	Order code P2	Order code P3	Order code P4
#0 - #6	.141	.110	1001	1006			
#8	.168	.131	1002	1007			
#10	.194	.152	1003	1008	1016		
#12	.220	.165	1004	1009			
1/4"	.255	.191	1005	1010	1017		
5/16"	.318	.238		1012	1018		
3/8"	.381	.286		1013	1019		
7/16"	.323	.242		1014	1020		
1/2"	.367	.275		1015	1021		
9/16"	.429	.322		10155	1022		
1/8" Pipe	.313	.234		10166	10266		
1/8" Pipe	.438	.328		10177	10277		
5/8"	.480	.360			1023		
11/16"	.542	.406			1024		
3/4"	.590	.442			1025		10392
13/16"	.652	.489			1026	1031	
7/8"	.697	.523			1027	1032	
1/4" Pipe	.562	.421			10288		
3/8" Pipe	.700	.531			10299	10386	
1/2" Pipe	.687	.515			10300	10387	
15/16"	.760	.570				1033	
1"	.800	.600				1034	10391
1 1/8"	.896	.672				1035	10393
1 1/4"	1.021	.766				1036	1039
1 3/8"	1.108	.831				1037	1040
3/4" Pipe	.906	.679				10388	10440
1" Pipe	1.125	.843				10389	10442
1 1/2"	1.233	.925					1041
1 5/8"	1.305	.979					1042
1 3/4"	1.430	1.072					1043
1 7/8"	1.519	1.139					10435
1 1/4" Pipe	1.312	.984					10444
1 1/2" Pipe	1.500	1.125					10455
2"	1.644	1.233					1044

## Quick-change adapters, positive drive *metric sizes*

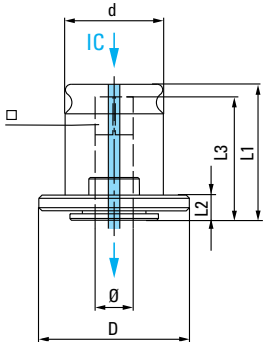

For quick change tap chucks TA, TIC, NC and SPD QC with or without internal coolant system.

### Features and Advantages

- equally appropriate for taps with internal coolant
- no pre-selective torque drive
- suitable for right and left hand tapping

Model	Adapter Size	Dimensions			
		d mm	L1 mm	D mm	L2 mm
P0	0	13	26.5	22	7
P1	1	19	28.5	30	7
P2	2	31	46.5	48	11
P3	3	48	68.5	70	14
P4	4	60	105.0	92	42

### Quick change adapters, positive drive metric sizes

Tap	Shank Ømm	Square mm	Order code P0	Order code P1	Order code P2	Order code P3	Order code P4
M2, M2.5, M4	2.8	2.1	P0-028021				
M3, M5	3.5	2.7	P0-035027	P1-035027			
M3.5	4	3	P0-040030	P1-040030			
M4	4.5	3.4	P0-045034	P1-045034			
M4, M4.5	5	4	P0-050040	P1-050040			
M4.5, M5, M6, M8	6	4.9	P0-060049	P1-060049	P2-060049		
M8	8	6.2	P0-080062*	P1-080062	P2-080062		
M7, M9, M10	7	5.5	P0-070055*	P1-070055	P2-070055		
M12	9	7		P1-090070	P2-090070		
M10	10	8		P1-100080	P2-100080		
M14	11	9		P1-110090		P3-110090	
M16	12	9			P2-120090	P3-120090	
M18	14	11			P2-140110	P3-140110	
M20	16	12			P2-160120	P3-160120	
M22, M24, M25, M26	18	14.5			P2-180145	P3-180145	P4-180145
M27, M28	20	16				P3-200160	P4-200160
M30, M32	22	18				P3-220180	P4-220180
M33	25	20				P3-250200	P4-250200
M34, M35, M36, M38	28	22				P3-280220	P4-280220
M39, M40, M42	32	24					P4-320240
M45, M48, M50	36	29					P4-360290

**Note:** Version with (\*) only suitable for light processing

**Note:** other sizes available on request.

## Quick-change adapters, with pre-selective torque drive *inch sizes*

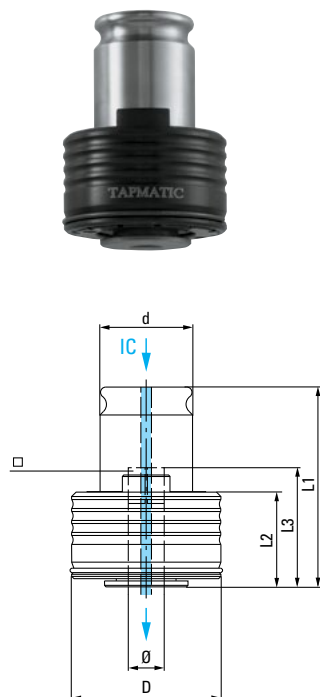

For quick change tap chucks TA, TIC, NC and SPD QC, with or without internal coolant system. A pre-selective torque drive protects the tap from breakage.

### Features and Advantages

- equally appropriate for taps with internal coolant
- with pre-selective torque drive
- suitable for right and left hand tapping

Model	Adapter Size	Dimensions			
		d mm	L1 mm	D mm	L2 mm
TC0	0	13	40.5	23	21
TC1	1	19	46.5	32	25
TC2	2	31	69	50	34
TC3	3	48	100.5	72	45
TC4	4	60	131	95	68

### Product range – Adapters with torque control

Tap	Shank Ø inch	Square inch	Order code TC0	Order code TC1	Order code TC2	Order code TC3	Order code TC 4
#0 - #6	.141	.110	1046	1051			
#8	.168	.131	1047	1052			
#10	.194	.152	1048	1053			
#12	.220	.165	1049	1054			
1/4"	.255	.191	1050	1055	10614		
5/16"	.318	.238		1056	1062		
3/8"	.381	.286		1057	1063		
7/16"	.323	.242		1058	1064		
1/2"	.367	.275		1059	1065		
9/16"	.429	.322		10595	1066		
1/8" Pipe	.313	.234		10600			
1/8" Pipe	.438	.328		10611			
5/8"	.480	.360			1067		
11/16"	.542	.406			1068		
3/4"	.590	.442			1069	1074	
13/16"	.652	.489			1070	1075	
7/8"	.697	.523			1071	1076	
1/4" Pipe	.562	.421			10722		
3/8" Pipe	.700	.531			10733	1082	
1/2" Pipe	.687	.515			10744	10821	
15/16"	.760	.570				1077	
1"	.800	.600			10711	1078	10835
1 1/8"	.896	.672				1079	10836
1 1/4"	1.021	.766				1080	10837
1 3/8"	1.108	.831				1081	1084
3/4" Pipe	.906	.679				10822	10880
1" Pipe	1.125	.843				10833	10882
1 1/2"	1.233	.925					1085
1 5/8"	1.305	.979					1086
1 3/4"	1.430	1.072					1087
1 7/8"	1.519	1.139					10875
1 1/4" Pipe	1.312	.984					10899
1 1/2" Pipe	1.500	1.125					10900



## Quick-change adapters, with pre-selective torque drive *metric sizes*

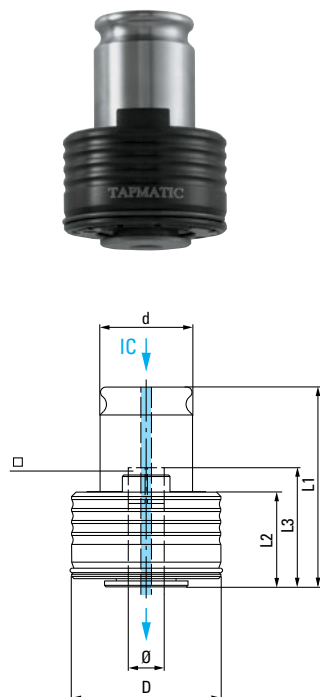

For quick change tap chucks TA, TIC, NC and SPD QC, with or without internal coolant system. A pre-selective torque drive protects the tap from breakage.

### Features and Advantages

- equally appropriate for taps with internal coolant
- with pre-selective torque drive
- suitable for right and left hand tapping

Model	Adapter Size	Dimensions			
		d mm	L1 mm	D mm	L2 mm
TC0	0	13	40.5	23	21
TC1	1	19	46.5	32	25
TC2	2	31	69	50	34
TC3	3	48	100.5	72	45
TC4	4	60	131	95	68

### Product range – Adapters with torque control

Tap	Shank Ø mm	Square mm	Order code TC0	Order code TC1	Order code TC2	Order code TC3	Order code TC4
M2, M2.5, M4	2.8	2.1	TC0-028021				
M3, M5	3.5	2.7	TC0-035027	TC1-035027			
M3.5	4	3	TC0-040030	TC1-040030			
M4	4.5	3.4	TC0-045034	TC1-045034			
M4, M4.5	5	4	TC0-050040	TC1-050040			
M4.5, M5, M6, M8	6	4.9	TC0-060049	TC1-060049	TC2-060049		
M8	8	6.2	TC0-080062*	TC1-080062	TC2-080062		
M7, M9, M10	7	5.5	TC0-070055*	TC1-070055	TC2-070055		
M12	9	7		TC1-090070	TC2-090070		
M10	10	8		TC1-100080	TC2-100080		
M14	11	9		TC1-110090	TC2-110090	TC3-110090	
M16	12	9			TC2-120090	TC3-120090	
M18	14	11			TC2-140110	TC3-140110	
M20	16	12			TC2-160120	TC3-160120	
M22, M24, M25, M26	18	14.5			TC2-180145	TC3-180145	TC4-180145
M27, M28	20	16				TC3-200160	TC4-200160
M30, M32	22	18				TC3-220180	TC4-220180
M33	25	20				TC3-250200	TC4-250200
M34, M35, M36, M38	28	22				TC3-280220	TC4-280220
M39, M40, M42	32	24					TC4-320240
M45, M48, M50	36	29					TC4-360290

**Note:** Version with (\*) only suitable for light processing

## Quick-change collet chuck adapters for rubber flex collets (RF)

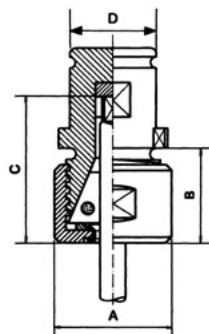

Tap holders with various or adjustable back jaws for quick change tap chucks TA and NC. Only 2 multi-range collets (RF) per type necessary to cover capacity.

### Delivery

Accessories include wrench and necessary square drives for the specified capacity. Please note that rubber flex collets are also included

Model	Order code	Tap size	Collets Rubber Flex Included	Dimensions			
				A mm	B mm	C mm	D mm
TF0	29350	M1.4–M7	21600	18.6	18.6	21.0	13
			21700				
TF1	29351	M3–M12	22100	27.4	18.6	27.0	19
			22200				
TF2	29352	M5–M18	24100	37.2	24.6	38.1	31
			24500				
TF3	29353	M10–M30	26100	54.0	31.8	50.5	48
			26200				

## Rubber Flex multi-range collets



Rubber Flex collets for TAPMATIC tapping attachments and chucks.

Tapping Head capacity	RF Collet Order code	Clamping Capacity (mm)	Tap Capacity Metric Sizes (DIN 371, 374)	Tap Capacity Inch Sizes	Standard or Special Size
M1.4 - M7 #0 - 1/4"	21500	1.0–2.5	M1.6	None	Special
	21600	2.5–4.5	M1.6-M4	#0-#8	Standard
	21700	4.5–6.5	M4-M6	#10-1/4"	Standard
M3 - M12 #6 - 1/2"	22000	4.5–8.0	M4-M10	#10-1/4"	Special
	22100	3.5–6.5	M3-M6	#0-1/4"	Standard
	22200	6.5–10.0	M7-M12	5/16"-1/2"	Standard
	22300	2.0–4.5	M1.6-M4	#0-#8	Special
M5 - M18 #10 - 3/4"	24000	7.0–13.0	M7-M16	5/16"-5/8"	Special
	24100	4.5–10.0	M4-M12	#10-1/2"	Standard
	24300	2.8–7.0	M2-M7	#0-1/4"	Special
	24500	9.0–15.0	M10-M18	1/2"-3/4"	Standard
M10 - M30 1/2" - 1 1/8"	26100	10.0–16.0	M10, M14-M20	9/16"-3/4"	Standard
	26200	16.0-23.0	M20-M30	13/16"-1 1/8"	Standard

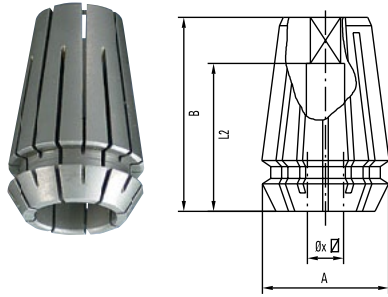
Steel collets ER-GB with inner square *metric sizes*

Collets to DIN 6499B with inner square for positive drive of tap square.

## ER11GB

Order code	A = 11.5 mm B = 17.0 mm	
	Shank mm	Square mm
GB111028	2.8	2.1
GB111035	3.5	2.7
GB111045	4.5	3.4
GB111050	5.0	4.0
GB111060	6.0	4.9

## ER16GB

Order code	A = 17.0 mm B = 27.5 mm	
	Shank mm	Square mm
GB116040	4.0	3.15/3.2
GB116045	4.5	3.4
GB116050	5.0	4.0
GB116053	5.5	4.3
GB116055	5.5	4.5
GB116065	6.0	4.5
GB116060	6.0	4.9
GB116062	6.2	5.0
GB116063	6.3	5.0
GB116070	7.0	5.5
GB116071	7.1	5.6
GB116080	8.0	6.2/6.3
GB116085	8.5	6.5
GB116090	9.0	7.0/7.1

## ER20GB

Order code	A = 21.0 mm B = 31.5 mm	
	Shank mm	Square mm
GB120040	4.0	3.15/3.2
GB120045	4.5	3.4
GB120050	5.0	4.0
GB120053	5.5	4.3
GB120055	5.5	4.5
GB120065	6.0	4.5
GB120060	6.0	4.9
GB120062	6.2	5.0
GB120063	6.3	5.0
GB120070	7.0	5.5
GB120071	7.1	5.6
GB120080	8.0	6.2/6.3
GB120085	8.5	6.5
GB120090	9.0	7.0/7.1
GB120100	10.0	8.0
GB120105	10.5	8.0
GB120110	11.0	9.0
GB120112	11.2	9.0
GB120120	12.0	9.0

## ER25GB

Order code	A = 26.0 mm B = 34.0 mm	
	Shank mm	Square mm
GB125040	4.0	3.15/3.2
GB125045	4.5	3.4
GB125050	5.0	4.0
GB125053	5.5	4.3
GB125055	5.5	4.5
GB125065	6.0	4.5
GB125060	6.0	4.9
GB125062	6.2	5.0
GB125063	6.3	5.0
GB125070	7.0	5.5
GB125071	7.1	5.6
GB125080	8.0	6.2/6.3
GB125085	8.5	6.5
GB125090	9.0	7.0/7.1
GB125100	10.0	8.0
GB125105	10.5	8.0
GB125110	11.0	9.0
GB125112	11.2	9.0
GB125120	12.0	9.0
GB125125	12.5	10.0
GB125140	14.0	11.0/11.2
GB125150	15.0	12.0
GB125160	16.0	12.0

## ER32GB

Order code	A = 33.0 mm B = 40.0 mm	
	Shank mm	Square mm
GB132040	4.0	3.15/3.2
GB132045	4.5	3.4
GB132050	5.0	4.0
GB132053	5.5	4.3
GB132055	5.5	4.5
GB132065	6.0	4.5
GB132060	6.0	4.9
GB132062	6.2	5.0
GB132063	6.3	5.0
GB132070	7.0	5.5
GB132071	7.1	5.6
GB132080	8.0	6.2/6.3
GB132085	8.5	6.5
GB132090	9.0	7.0/7.1
GB132100	10.0	8.0
GB132105	10.5	8.0
GB132110	11.0	9.0
GB132112	11.2	9.0
GB132120	12.0	9.0
GB132125	12.5	10.0
GB132140	14.0	11.0/11.2
GB132150	15.0	12.0
GB132160	16.0	12.0
GB132170	17.0	13.0
GB132180	18.0	14.0/14.5
GB132200	20.0	16.0

## ER40GB

Order code	A = 41.0 mm B = 46.0 mm	
	Shank mm	Square mm
GB140065	6.0	4.5
GB140060	6.0	4.9
GB140062	6.2	5.0
GB140063	6.3	5.0
GB140070	7.0	5.5
GB140071	7.1	5.6
GB140080	8.0	6.2/6.3
GB140085	8.5	6.5
GB140090	9.0	7.0/7.1
GB140100	10.0	8.0
GB140105	10.5	8.0
GB140110	11.0	9.0
GB140112	11.2	9.0
GB140120	12.0	9.0
GB140125	12.5	10.0
GB140140	14.0	11.0/11.2
GB140150	15.0	12.0
GB140160	16.0	12.0
GB140170	17.0	13.0
GB140180	18.0	14.0/14.5
GB141200	20.0	16.0
GB141220	22.0	18.0

## ER50GB

Order code	A = 60.0 mm B = 52.0 mm	
	Shank mm	Square mm
GB150220	22.0	18.0
GB150250	25.0	20.0
GB150280	28.0	22.0
GB150320	32.0	24.0

Steel collets ER-GB with inner square *inch* sizes

ER11GB						
Order code	Tap size	Shank inch	Square inch	A	B	L2
21000	#0 - #6	.141	.110	.444	.708	.472
21001	#8	.168	.131	.444	.708	.551
21002	#10	.194	.152	.444	.708	.551

ER16GB						
Order code	Tap size	Shank inch	Square inch	A	B	L2
21004	#0 - #6	.141	.110	.629	1.083	.709
21005	#8	.168	.131	.629	1.083	.709
21006	#10	.194	.152	.629	1.083	.709
21008	#12	.220	.165	.629	1.083	.709
21010	1/4"	.255	.191	.629	1.083	.709
21012	5/16"	.318	.238	.629	1.083	.866
21014	7/16"	.323	.242	.629	1.083	.866

ER20GB						
Order code	Tap size	Shank inch	Square inch	A	B	L2
21019	#8	.168	.131	.787	1.240	.709
21020	#10	.194	.152	.787	1.240	.709
21021	#12	.220	.165	.787	1.240	.709
21022	1/4"	.255	.191	.787	1.240	.709
21023	5/16"	.318	.238	.787	1.240	.866
21024	7/16"	.323	.242	.787	1.240	.866
21025	1/2"	.367	.275	.787	1.240	.866
21026	3/8"	.381	.286	.787	1.240	.866
21027	1/16" Pipe	.3125	.234	.787	1.240	.866

ER25GB						
Order code	Tap size	Shank inch	Square inch	A	B	L2
21031	1/4"	.255	.191	.984	1.338	.709
21029	5/16"	.318	.238	.984	1.338	.866
21030	7/16"	.323	.242	.984	1.338	.866
21032	1/2"	.367	.275	.984	1.338	.866
21034	3/8"	.381	.286	.984	1.338	.866
21036	9/16"	.429	.322	.984	1.338	.984
21038	5/8"	.480	.360	.984	1.338	.984
21040	11/16"	.542	.406	.984	1.338	.984
21028	1/8" Pipe	.312	.234	.984	1.338	.866
21037	1/8" Pipe	.437	.328	.984	1.338	.984
21043	1/4" Pipe	.562	.421	.984	1.338	.984
21044	3/4"	.590	.442	.984	1.338	.984

ER32GB						
Order code	Tap size	Shank inch	Square inch	A	B	L2
21047	1/4"	.255	.191	1.260	1.575	.709
21048	5/16"	.318	.238	1.260	1.575	.866
21049	7/16"	.323	.242	1.260	1.575	.866
21052	3/8"	.381	.286	1.260	1.575	.866
21050	1/2"	.367	.275	1.260	1.575	.866
21054	9/16"	.429	.322	1.260	1.575	.984
21058	5/8"	.480	.360	1.260	1.575	.984
21060	11/16"	.542	.406	1.260	1.575	.984
21064	3/4"	.590	.442	1.260	1.575	.984
21066	13/16"	.652	.489	1.260	1.575	.984
21068	7/8"	.697	.523	1.260	1.575	.984
21056	1/8" Pipe	.437	.328	1.260	1.575	.984
21062	1/4" Pipe	.562	.421	1.260	1.575	.984
21067	1/2" Pipe	.687	.515	1.260	1.575	.984
21070	1"	.800	.600	1.260	1.575	1.102

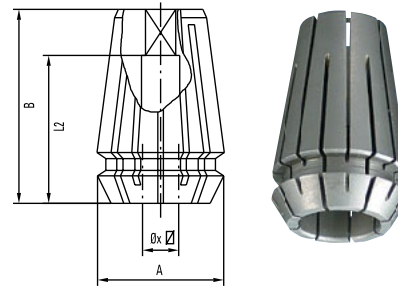

ER40GB						
Order code	Tap size	Shank inch	Square inch	A	B	L2
21104	1/2"	.367	.275	1.575	1.811	.866
21105	3/8"	.381	.286	1.575	1.811	.866
21106	9/16"	.429	.322	1.575	1.811	.984
21107	5/8"	.480	.360	1.575	1.811	.984
21108	11/16"	.542	.406	1.575	1.811	.984
21109	3/4"	.590	.442	1.575	1.811	.984
21110	13/16"	.652	.489	1.575	1.811	.984
21111	7/8"	.697	.523	1.575	1.811	.984
21112	15/16"	.760	.570	1.575	1.811	.984
21113	1"	.800	.600	1.575	1.811	1.102
21117	1 1/8"	.896	.672	1.575	1.811	1.102
21114	1/4" Pipe	.562	.421	1.575	1.811	.984
21115	3/8" Pipe	.700	.531	1.575	1.811	.984
21116	1/2" Pipe	.687	.515	1.575	1.811	.984

ER50GB			
Order code	Tap size	Shank inch	Square inch
21137	1"	.800	.600
21138	1 1/8"	.896	.672
21139	1 3/16"	1.021	.766
21140	1 5/16"	1.108	.831
21141	1 7/16"	1.233	.925
21170	1/2" Pipe	.687	.515
21171	3/8" Pipe	.700	.531
21172	3/4" Pipe	.906	.679
21136	1" Pipe	1.125	.843

## Steel collets ER acc. to DIN 6499B without inner square

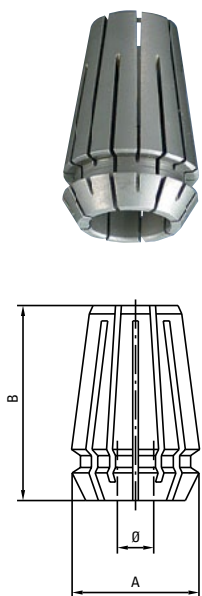

ER8	
A = 8.5 mm B = 12.0 mm	
Order code	Capacity Shank Ø mm
20910	1.5–1.0
20911	2.0–1.5
20912	2.5–2.0
20913	3.0–2.5
20915	3.5–3.0
20916	4.0–3.5
20918	4.5–4.0

ER11	
A = 11.5 mm B = 17.0 mm	
Order code	Capacity Shank Ø mm
20929	3.0–2.5
20930	3.5–3.0
20931	4.0–3.5
20932	4.5–4.0
20934	5.0–4.5
20933	5.5–5.0
20935	6.0–5.5
20936	6.5–6.0

ER16	
A = 17.0 mm B = 27.5 mm	
Order code	Capacity Shank Ø mm
20940	4.0–3.0
20943	5.0–4.0
20945	6.0–5.0
20946	7.0–6.0
20949	8.0–7.0
20950	9.0–8.0
20953	10.0–9.0

ER20	
A = 21.0 mm B = 31.5 mm	
Order code	Capacity Shank Ø mm
20983	4.0–3.0
20984	5.0–4.0
20985	6.0–5.0
20977	7.0–6.0
20986	8.0–7.0
20978	9.0–8.0
20979	10.0–9.0
20980	11.0–10.0
20981	12.0–11.0
20982	13.0–12.0

ER25	
A = 26.0 mm B = 34.0 mm	
Order code	Capacity Shank Ø mm
20963	5.0–4.0
20965	7.0–6.0
20968	9.0–8.0
20969	10.0–9.0
20970	11.0–10.0
20971	12.0–11.0
20973	13.0–12.0
20974	14.0–13.0
20975	15.0–14.0
20976	16.0–15.0

Please note that these collets *do not* include a square drive.  
For tapping we recommend the use of ERGB collets, with inner square, whenever possible.  
All dimensions are shown in mm. 25.4mm = 1"

### Clamping nuts acc. to DIN 6499 standard without internal coolant sealing

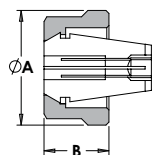

**Note:** For recommended tightening torque, please see page 56.

Order code	Type	A mm	B mm
69318	ER11	19	11.3
69518	ER16	28	17.5
70018	ER20	34	19.0

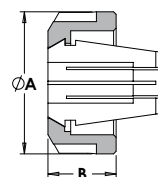

Order code	Type	A mm	B mm
69918	ER25	42	20.0
71118	ER32	50	22.5
71318	ER40	63	25.5
66018	ER50	78	35.3

### Clamping nuts to DIN 6499 for internal coolant system, for use with sealing disks

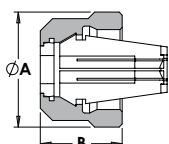
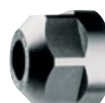

Order code	Type	A mm	B mm
70116	ER16	28	22.5
70120	ER20	34	24.5

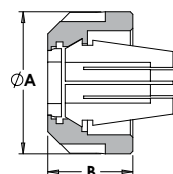

Order code	Type	A mm	B mm
70125	ER25	42	25.0
70132	ER32	50	27.5
70140	ER40	63	30.5
66050	ER50	78	42.5

### Steel collet seals for use with coolant through steel collet models and sealing disk nuts.

Description #16 Series Seals	
Size	Catalog No.
<b>Complete Set</b>	70117
3-3.5mm (.118-.138)	70117-35
3.5-4mm (.138-.157)	70117-40
4-4.5mm (.157-.177)	70117-45
4.5-5mm (.177-.197)	70117-50
5-5.5mm (.197-.217)	70117-55
5.5-6mm (.217-.236)	70117-60
6-6.5mm (.236-.256)	70117-65
6.5-7mm (.256-.276)	70117-70
7-7.5mm (.276-.295)	70117-75
7.5-8mm (.295-.315)	70117-80
8-8.5mm (.315-.335)	70117-85
8.5-9mm (.335-.354)	70117-90
9-9.5mm (.354-.374)	70117-95
9.5-10mm (.374-.394)	70117-100

Description #20 Series Seals	
Size	Catalog No.
<b>Complete Set</b>	70121
3-3.5mm (.118-.138)	70121-35
3.5-4mm (.138-.157)	70121-40
4-4.5mm (.157-.177)	70121-45
4.5-5mm (.177-.197)	70121-50
5-5.5mm (.197-.217)	70121-55
5.5-6mm (.217-.236)	70121-60
6-6.5mm (.236-.256)	70121-65
6.5-7mm (.256-.276)	70121-70
7-7.5mm (.276-.295)	70121-75
7.5-8mm (.295-.315)	70121-80
8-8.5mm (.315-.335)	70121-85
8.5-9mm (.335-.354)	70121-90
9-9.5mm (.354-.374)	70121-95
9.5-10mm (.374-.394)	70121-100
10-10.5mm (.394-.413)	70121-105
10.5-11mm (.416-.433)	70121-110
11-11.5mm (.433-.453)	70121-115
11.5-12mm (.453-.472)	70121-120
12-12.5mm (.472-.492)	70121-125

Description #25 Series Seals	
Size	Catalog No.
<b>Complete Set</b>	70126
3-3.5mm (.118-.138)	70126-35
3.5-4mm (.138-.157)	70126-40
4-4.5mm (.157-.177)	70126-45
4.5-5mm (.177-.197)	70126-50
5-5.5mm (.197-.217)	70126-55
5.5-6mm (.217-.236)	70126-60
6-6.5mm (.236-.256)	70126-65
6.5-7mm (.256-.276)	70126-70
7-7.5mm (.276-.295)	70126-75
7.5-8mm (.295-.315)	70126-80
8-8.5mm (.315-.335)	70126-85
8.5-9mm (.335-.354)	70126-90
9-9.5mm (.354-.374)	70126-95
9.5-10mm (.374-.394)	70126-100
10-10.5mm (.394-.413)	70126-105
10.5-11mm (.416-.433)	70126-110
11-11.5mm (.433-.453)	70126-115
11.5-12mm (.453-.472)	70126-120
12-12.5mm (.472-.492)	70126-125
12.5-13mm (.492-.512)	70126-130
13-13.5mm (.512-.531)	70126-135
13.5-14mm (.531-.551)	70126-140
14-14.5mm (.551-.571)	70126-145
14.5-15mm (.571-.591)	70126-150
15-15.5mm (.591-.610)	70126-155
15.5-16mm (.610-.630)	70126-160

Description #32 Series Seals	
Size	Catalog No.
<b>Complete Set</b>	70133
3-3.5mm (.118-.138)	70133-35
3.5-4mm (.138-.157)	70133-40
4-4.5mm (.157-.177)	70133-45
4.5-5mm (.177-.197)	70133-50
5-5.5mm (.197-.217)	70133-55
5.5-6mm (.217-.236)	70133-60
6-6.5mm (.236-.256)	70133-65
6.5-7mm (.256-.276)	70133-70
7-7.5mm (.276-.295)	70133-75
7.5-8mm (.295-.315)	70133-80
8-8.5mm (.315-.335)	70133-85
8.5-9mm (.335-.354)	70133-90
9-9.5mm (.354-.374)	70133-95
9.5-10mm (.374-.394)	70133-100
10-10.5mm (.394-.413)	70133-105
10.5-11mm (.416-.433)	70133-110
11-11.5mm (.433-.453)	70133-115
11.5-12mm (.453-.472)	70133-120
12-12.5mm (.472-.492)	70133-125
12.5-13mm (.492-.512)	70133-130
13-13.5mm (.512-.531)	70133-135
13.5-14mm (.531-.551)	70133-140
14-14.5mm (.551-.571)	70133-145
14.5-15mm (.571-.591)	70133-150
15-15.5mm (.591-.610)	70133-155
15.5-16mm (.610-.630)	70133-160
16-16.5mm (.630-.650)	70133-165
16.5-17mm (.650-.670)	70133-170
17-17.5mm (.670-.690)	70133-175
17.5-18mm (.690-.710)	70133-180
18-18.5mm (.710-.730)	70133-185
18.5-19mm (.730-.748)	70133-190
19-19.5mm (.749-.767)	70133-195
19.5-20mm (.767-.787)	70133-200



**Note:** #40 and #50 seals also available on request

Also available, coolant flush disks for directing coolant down the tap shank.



■ on request



**Torque wrenches. For recommended tightening torque, please see page 56**

**Clamping device for ER collet chuck SFTTools**



For easy and controlled tightening of nuts for collet chuck holders, without damaging the tool. For use with SFT10, 50, 75 and 100.

Order code	Length mm
28SFT132	132
28SFT240	240

Holds collet chuck allowing you to tighten collet nut with a torque wrench. See page 56.

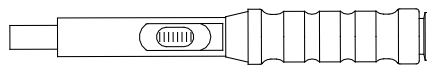

Order code	Model
7150.02025	Torco-Fix 0
7150.05050	Torco-Fix I
7150.20200	Torco-Fix II
7150.60300	Torco-Fix III
7159.09000	TSD 0.9

**Clip-on wrenches for torque wrench**

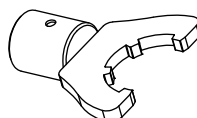

Order code	Model
7151.16000	A-E 16
7151.20000	A-E 20
7151.25000	A-E 25
7151.32000	A-E 32
7151.40000	A-E 40
7151.50000	A-E 50

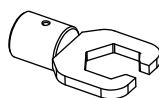

Order code	Model
7152.11010	A-E 11 P
7152.16010	A-E 16 P
7152.20010	A-E 20 P

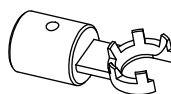

Order code	Model
7153.08000	A-E 8 M
7153.11000	A-E 11 M
7153.16000	A-E 16 M
7153.20000	A-E 20 M
7153.25000	A-E 25 M

**Quill Mount Torque Bars – clamp around quill of machine for use with Manual Tapping Attachments**



Order code	Diameter	Capacity
V-Typ 29099	38–60 mm 1 1/2"–2 3/8"	M16 1/2"
290991	60–114 mm 2 3/8"–4 1/2"	M18 3/4"

Always mount a torque bar to hold the tapping attachment's stop arm from rotating. The stop arm should not be installed permanently, not under any circumstances be held by hand or fastened with wire. The torque bar must be mounted securely to the table or quill of your machine. The torque bar installation must be stronger than the largest tap in the capacity range of your tapping attachment. Please order Tapmatic torque bars shown.

**Table Mount Torque Bars – mount to the «T» slots of table**



Order code	Tap capacity
29096	M33 1 3/4"



Order code	Tap capacity
29097	M18 3/4"

**NC shanks DIN 69871A/D and CAT**

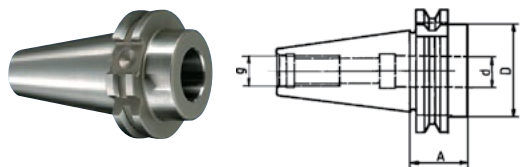

Order code DIN 69871	Shank	Bore d mm	Dimensions mm			Weight kg
			D	A	g	
S-241	SK40	20	45	35	M16	0.9
S-242	SK40	25	45	35	M16	0.8
S-244	SK40	40	90	122	M16	2.6
S-251	SK50	20	72	35	M24	2.9
S-252	SK50	25	72	35	M24	2.8
S-254	SK50	40	90	112	M24	4.9

Order code CAT	Shank	Bore d mm	Dimension			Weight kg
			D	A	g	
23951	CAT40	1"	1.75"	1.38"	5/8"-11	0.7
23947	CAT40	25mm	45mm	35mm	5/8"-11	0.7
23954	CAT45	1"	2.25"	1.38"	3/4"-10	1.6
23953	CAT50	1"	2.75"	1.38"	1"-8	2.7
23948	CAT50	25mm	70mm	35mm	1"-8	2.7
23957	CAT50	1 1/2"	2.75"	2.00"	1"-8	2.7
23964	CAT50	40mm	70mm	75mm	1"-8	4.9

**NC shanks MAS-BT**

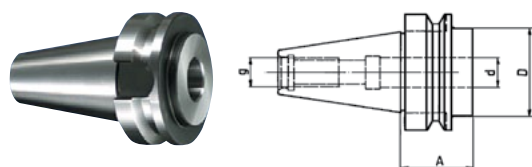

Order code BT	Arbors	Bore d	Dimensions mm			Weight kg
			D	A	g	
23949	BT30	1"	1.81"	1.50"	M12	0.4
23958	BT35	1"	1.50"	1.38"	M16	0.4
23943	BT40	25mm	45mm	35mm	M16	0.8
23952	BT40	1"	1.75"	1.38"	M16	0.8
23955	BT50	1"	2.75"	1.88"	M24	3.6
23945	BT50	25mm	70mm	48mm	M24	3.6
S-354	BT50	40mm	90mm	110mm	M24	5.3

**Modular NC shanks HSK-A**

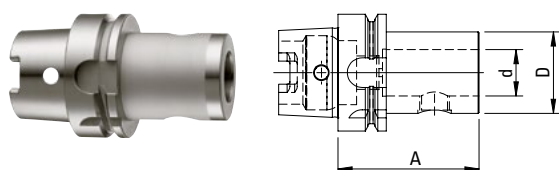

Order code	Shank HSK-A	Bore d mm	Dimensions mm			Weight kg
			D	A	g	
S-451	HSK50	25	44	76	0.8	
S-461	HSK63	25	44	76	1.0	
S-463	HSK63A	40	72	120	2.6	
S-481	HSK80	25	65	100	2.7	
S-411	HSK100	25	65	100	3.5	
S-413	HSK100A	40	80	105	4.7	

**NC shanks DIN 2080 and NMTB**

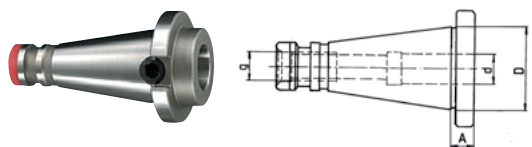

Order code DIN 2080	Shank	Bore d mm	Dimensions mm			Weight kg
			D	A	g	
S-141	SK40	20	44	24	M16	0.7
S-142	SK40	25	44	24	M16	0.6
S-151	SK50	20	65	34	M24	2.5
S-152	SK50	25	65	34	M24	2.4

Order code NMTB	Shank	Bore d	Dimensions			Weight kg
			D	A	g	
23950	NMTB40	1"	1.75"	.039"	5/8"-11	0.5

**NMTB with threaded mount**



Order code	NMTB	Thread
23050	NMTB-30	1/2-20
24050	NMTB-40	1/2-20
23087	NMTB-30	7/8-20
24087	NMTB-40	7/8-20
23015	NMTB-30	1 1/2-18
24015	NMTB-40	1 1/2-18
25015	NMTB-50	1 1/2-18
29106	NMTB-50	2 1/4-10

**Reducing sleeve**

Order code	Outside Ø	Inside Ø
23921	1"	3/4"

**R8 arbors to Jacobs taper**



Order code	R8	Jacobs Taper
20833	R-8 Bridgeport	#33 J.T.
20803	R-8 Bridgeport	#3 J.T.
20804	R-8 Bridgeport	#4 J.T.

**R8 arbors with threaded mount**



Order code	R8	Thread
20887	R-8 Bridgeport	7/8"-20
20815	R-8 Bridgeport	1 1/2"-18

**Morse taper arbors to JACOBS taper**

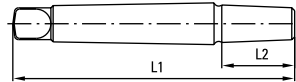

Order code	Morse taper	DIN Taper	Length mm	
			L1	L2
20112	MK1	B12	91	22
20116	MK1	B16	98	29
20212	MT2	B12	107	22
20216	MK2	B16	114	29
20218	MK2	B18	122	37
20312	MK3	B12	126	22
20316	MK3	B16	133	29
20318	MK3	B18	141	37
20416	MK4	B16	160	29
20418	MK4	B18	168	37

Order code	Morse taper	JACOBS taper	Length mm	
			L1	L2
20101	MT1	1	86	18
20133	MT1	33	96	26
20206	MT2	6	96	26
20201	MT2	1	103	18
20233	MT2	33	111	26
20203	MT2	3	117	32
20306	MT3	6	117	43
20301	MT3	1	122	18
20333	MT3	33	130	26
20303	MT3	3	136	32
20304	MT3	4	147	43
20433	MT4	33	157	26
20403	MT4	3	162	32
20404	MT4	4	173	43
20504	MT5	4	205	43

**Morse taper arbors with threaded mount**

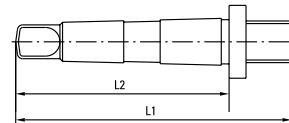

Order code	Morse taper	Thread	Length mm	
			L1	L2
20150	MT1	1/2-20	87	65.5
20250	MT2	1/2-20	103	80
20287	MT2	7/8-20	100	80
20387	MT3	7/8-20	116	99
20315	MT3	1 1/2-18	118	99
20487	MT4	7/8-20	142	124
20415	MT4	1 1/2-18	118	99
29104	MT4	2 1/4-10		
20515	MT5	1 1/2-18		
29105	MT5	2 1/4-10		

**Straight shank arbors to JACOBS taper**

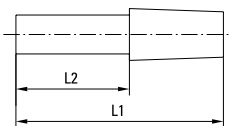

Order code	Straight shank Ø mm	JACOBS taper	Length mm	
			L1	L2
10-33	10	33	64	35
12-33	12	33	64	35
16-33	16	33	64	35

Order code	Straight shank Ø inch	JACOBS taper	Length mm	
			L1	L2
25001	1/2"	1		
25006	1/2"	6		
25033	1/2"	33		
25003	1/2"	3		
26233	5/8"	33		
26203	5/8"	3		
27533	3/4"	33		
27503	3/4"	3		
20003	1"	3		

**Straight shank arbors with threaded mount**



Order code	Straight shank Ø inch	Thread
25037	1/2" S.S.	3/8-24
25050	1/2" S.S.	1/2-20
25087	1/2" S.S.	7/8-20
26287	5/8" S.S.	7/8-20
27587	3/4" S.S.	7/8-20
28787	7/8" S.S.	7/8-20
20087	1" S.S.	7/8-20

**Installing Collet in Nut**

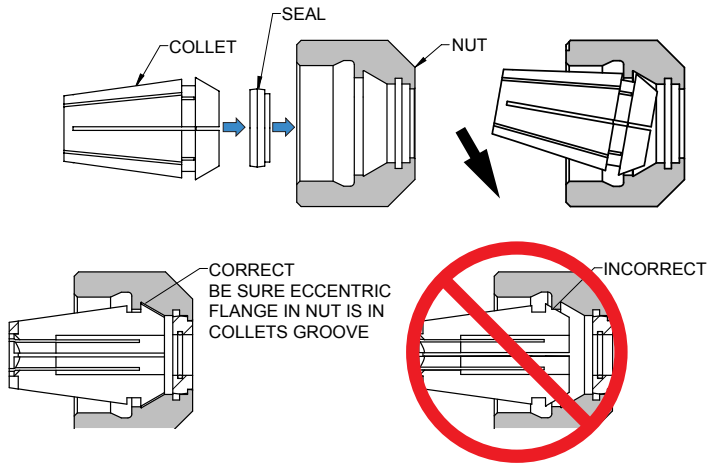

**Tightening**

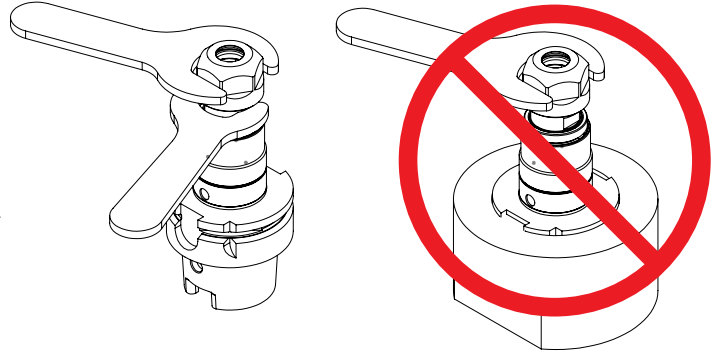

**Using a Torque Wrench**

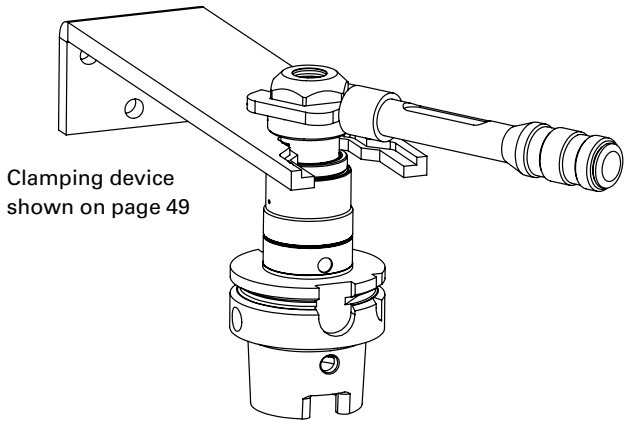

**Recommended clamping torque in Nm for collets**

GBTap Collets (With Square) should be used whenever possible

Type	Shank Ø	GB Collets (With Square)	Collets (Without Square)
ER 8	1.0 - 5.0 (.039 - .196")	-	6
ER 11	1.0 - 2.9 (.039 - .098)	8	8
Hi-Q	3.0 - 7.0 (.118 - .256")	16	24
ER 16	4.0 - 4.5 (.157 - .177")	40	Not Recommended
Hi-Q/ER C	5.0 - 10.0 (.197 - .394")	44	Not Recommended
ER 20	1.5 - 6.5 (.059 - .256")	32	Not Recommended
Hi-Q/ER C	7.0 - 13.0 (.276 - .512")	35	Not Recommended
ER 25	5.0 - 7.5 (.196 - .295")	80	Not Recommended
Hi-Q/ER C	8.0 - 17.0 (.315 - .669")	80	Not Recommended
ER 32	8.0 - 22.0 (.315 - .787")	136	Not Recommended
Hi-Q/ER C			
ER 40	6.0 - 26.0 (.236 - 1.023")	176	Not Recommended
Hi-Q/ER C			
ER 50	6.0 - 36.0 (.236 - 1.417")	300	See Note 2
Hi-Q/ER C			

Note 1: Maximum torque must not be more than 25% higher than above values

Note 2: For large taps with 36mm shank, a collet without square is used. There is a 29mm socket inside holder

**WARNING**

**To Avoid Serious Injury And Ensure Best Results For Your Tapping Operation, Please Read Carefully All Operator And Safety Instructions Provided For This Tapping Unit as well as all other safety instructions that are applicable, especially those for your machine tool.**

■ **1. Proper clothing:** The rotating spindle of a machine tool can snag loose fitting clothing, jewelry or long hair. Never wear jewelry, long sleeves, neckties, gloves or anything else that could become caught when operating a machine tool. Long hair must be restrained or netted to prevent it from becoming entangled in rotating spindle.

■ **2. Proper eye protection:** Always wear safety glasses with side shields to protect your eyes from flying particles.



■ **3. Proper work piece fixation:** Never hold the work piece or the vise it is held in, by hand. Never fasten it with wire or anything similar! The work piece must be clamped firmly to the table of the machine so that it cannot move, rotate or lift.



■ **4. On machining centers:** The same rule for stop arm and stop block installation applies «Always be sure that the installation is stronger than the largest tap.» Automatic tool changes should only be made on enclosed machines.



■ **5. The tapping attachment housing, drive spindle and tap itself can become hot to the touch after operation. Use caution when removing the attachment from the machine or handling.**

■ **6. Always be aware of the potential hazards of a machining operation:** Sometimes working with your machine can seem routine. You may find that you are no longer concentrating on the operation. A feeling of false security can lead to serious injury. Always be alert to the dangers of the machines with which you work. Always keep hands, body parts, clothing, jewelry and hair out of the areas of operation, when the machine spindle is rotating. Areas of operation include the immediate point of machining and all transmission components including the tapping attachment. Never bring your hand, other body parts or anything attached to your body into any of these areas until the machine spindle is completely stopped.

■ **7. Be aware of any other applicable safety instructions/ requirements.**

**Check List for good tapping**

1. Never use this unit before reading all safety instructions for this attachment as well as the machine it is to be used on.
2. Is tap sharp and of correct design for current job?
3. Is tap in proper alignment with drilled hole?
4. Is machine speed correct?
5. Is machine feed correct?
6. Is machine stop set properly so tap releases in neutral rather than bottoming in work piece or fixture?
7. Is drilled hole the correct size?
8. Is clearance between the drilled hole and tap sufficient at start position to allow the tap to clear the hole upon retraction?
9. Is the stop arm of the tapping attachment held rigidly against rotation. Stop Arm installation must be stronger than largest tap.
10. Is the proper cutting fluid or coolant being used for lubricating the tap?
11. If a bottom hole is being tapped is there sufficient chip clearance?
12. Is the correct Tapmatic model for the specific job requirement being used? (Capacity should be reduced by 25% for roll form taps.)

**TAPMATIC Warranty Policy**

Tapmatic Corporation warrants to original equipment manufacturers, distributors and industrial users of its products, that each new product manufactured or supplied by Tapmatic Corporation shall be free from defects in material and workmanship. Tapmatic Corporation's obligation under this warranty is limited to repairing any product which shall, within one year from the date of sale, be returned freight prepaid to Tapmatic Corporation, Post Falls, Idaho.

Any product returned for inspection for warranty repair consideration must be returned complete with chuck nut, back jaw and if the tool is a reversing unit, stop arm, as well as, complete information as to operating conditions, machine set up and application of cutting fluid.

The provision of this warranty shall not apply to any parts of a Tapmatic product subject to conditions, machine setup or application of cutting fluid or which has been repaired or altered if such repair or alteration, which in the judgement of Tapmatic Corporation, would adversely affect the performance of the product.

This warranty is in lieu of all other warranties, express or implied, including any implied warranty of merchantability or fitness for particular purpose. Tapmatic Corporation shall have no liability or responsibility on any claim of any kind, whether in contract, tort, or otherwise, for any loss or damage arising out of, connected with, or resulting from the manufacture, sale, delivery or use of any products sold hereunder in excess of the cost of repair as provided herein. In no event shall Tapmatic Corporation be liable for any special, incidental, or consequential damages.

Tapmatic Corporation makes no other warranties, express or implied, except as set forth above and Tapmatic Corporation neither assumes nor authorizes any other person or entity to assume for it any other obligation or liability in connection with any of its products.



24 hours a day, information is only a mouse click away

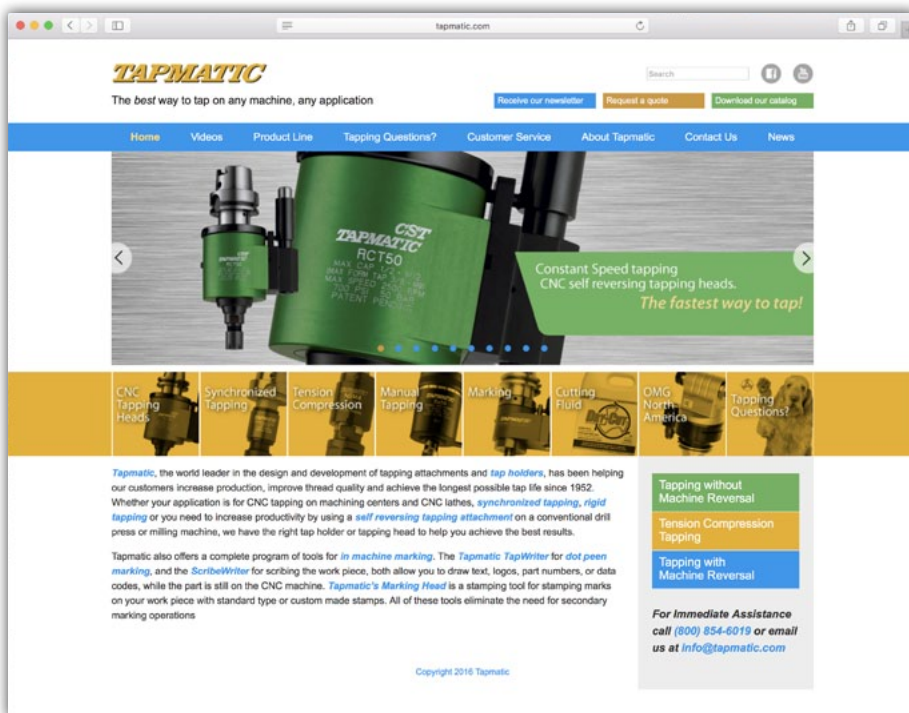

Our websites are a giant database with many useful features like:

- product information with detailed downloads
- general technical information about tapping, which will help you get the best possible results
- video demonstration of our tools in action
- the newest applications and innovations
- contact information of your local Tapmatic representative

Visit [www.tapmatic.com](http://www.tapmatic.com)

**O.M.G. World Leader in Angle Heads, Spindle Speeders and Multi-Spindle Heads.**

O.M.G. North America is a partnership between Tapmatic Corporation and O.M.G. srl offering the full range of O.M.G. products in the USA.

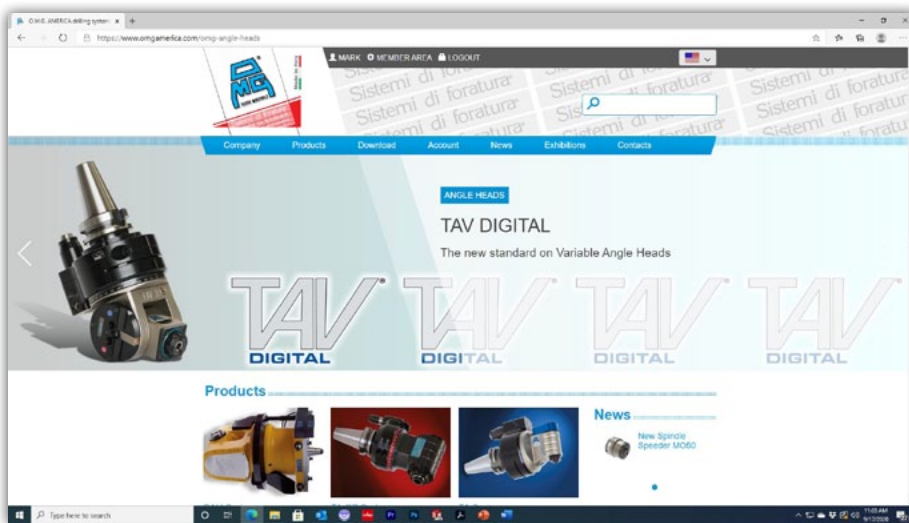

Visit [www.omgamerica.com](http://www.omgamerica.com)

Customer: \_\_\_\_\_ Date: \_\_\_\_\_

Contact person: \_\_\_\_\_ Department: \_\_\_\_\_

Address: \_\_\_\_\_

City: \_\_\_\_\_ State: \_\_\_\_\_ Postal Code: \_\_\_\_\_

Phone: \_\_\_\_\_ E-Mail: \_\_\_\_\_

Machine: \_\_\_\_\_

Model/Description: \_\_\_\_\_

vertical  horizontal

Shank type: \_\_\_\_\_ TAPMATIC Model: \_\_\_\_\_

Thread:  forming  cutting

Quantity:  through hole  bottom hole

Drill depth: \_\_\_\_\_ Tap Depth: \_\_\_\_\_ RPM: \_\_\_\_\_ Feed: \_\_\_\_\_

Material: \_\_\_\_\_ Internal coolant:  Yes  No

Remarks: \_\_\_\_\_

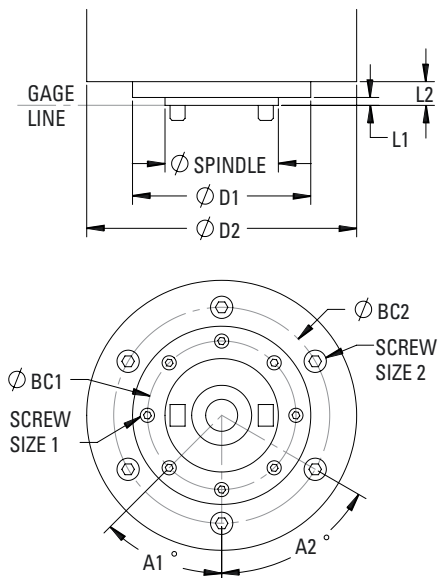

Machine Manufacturer	
Machine Model	
Machine Spindle Type	
Ø-Spindle	
Ø D1	
L1	
Ø BC1	
Screw Size 1	
Angle A1°	
Only if Applicable	
Ø D2	
L2	
Ø BC2	
Screw Size 2	
Angle A2°	



TAPMATIC is represented throughout the world.  
Please find your local dealer on:  
**www.tapmatic.com**



TAPMATIC Post Falls, USA

Headquarters:

**TAPMATIC Corporation**

802 Clearwater Loop, Post Falls, Idaho 83854, USA  
Phone 1 800 854-6019, or 001-208-773 29 51  
Fax 001-208-773 30 21  
info@tapmatic.com, www.tapmatic.com

European Service Center:

**TAPMATIC UK**

Millers Close Industrial Estate  
Fakenham Norfolk NR21 8NW  
Phone +44 1328 863676, Fax +44 1328 856118  
info@tapmatic.co.uk

Sold through: